



## TABLE OF CONTENTS

Safety Information and Warnings.....	2
Unpacking the Unit.....	3
Inventory.....	4
Glossary .....	5
Product Features.....	6
Mean Time Between Failure Statement.....	8
Description and Theory of Operation .....	9
Machine Preparation and Set-Up .....	12
Installation .....	14
Computer Network Communications .....	21
Configuring the System - User Inputs.....	22
Alarms .....	29
Configuring the Alarm Relays.....	30
Operation .....	31
Maintenance.....	32
Troubleshooting .....	33
Replacement Parts.....	48
Specifications .....	49
Appendix A - The ADH NETCOM AC NEMA Configuration .....	51
Appendix B - Communications Protocols .....	58
Appendix C - Master Configuration.....	63
Appendix D - Optional Front Panel.....	64
Ordering Information.....	70

## SAFETY INFORMATION AND WARNINGS



### Abnormal Odor or Smoke

In the event of smoke or a burning or abnormal odor, immediately interrupt power to the ADH NETCOM with the POWER switch at the rear of the unit, unplug the unit, or turn off the circuit breaker controlling the outlet. Note that only the AC model of the ADH NETCOM has an ON / OFF switch.

### Odeur ou fumée anormale

En cas de fumée ou de brûlure ou d'odeur anormale, coupez immédiatement l'alimentation de l'ADH NETCOM avec l'interrupteur POWER à l'arrière de l'appareil, débranchez l'appareil ou éteignez le disjoncteur contrôlant la prise. Notez que seul le modèle AC de l'ADH NETCOM a un interrupteur ON / OFF.



### Lethal Voltages Present

Lethal voltages are present inside the ADH NETCOM. Service should be performed by qualified personnel only. There are no user serviceable components inside the chassis.

### Tensions létales présentes

Des tensions mortelles sont présentes à l'intérieur du ADH NETCOM. L'entretien doit être effectué uniquement par du personnel qualifié. Il n'y a aucun composant réparable par l'utilisateur à l'intérieur du châssis.



### Pneumatics

Each of the air pumps inside the ADH NETCOM automatic air dehydrator is capable of generating as much as 24 psig (1,655mbar). Other attached dry air sources may be capable of generating even higher pressures. Proper safety practice requires treating all pneumatic components with care. Always vent the system to atmospheric pressure before servicing pneumatic components.

### Pneumatique

Chacune des pompes à air à l'intérieur du déshydrateur d'air automatique ADH NETCOM peut générer jusqu'à 24 psig (1 655 mbar). D'autres sources d'air sec fixées peuvent être capables de générer des pressions encore plus élevées. Une bonne pratique de sécurité nécessite de traiter tous les composants pneumatiques avec soin. Purgez toujours le système à la pression atmosphérique avant de procéder à l'entretien des composants pneumatiques.



### Rack Mounting

Before and after rack mounting the ADH NETCOM, ensure that the rack is stable. Mounting of the ADH NETCOM into a rack should be such that a hazardous condition is not created due to uneven mechanical loading. Verify that adequate air flow and power source capacity is available to the unit. Ensure that the ADH NETCOM maximum operating temperature of 130°F (55°C) will not be compromised by other components in the rack. Ensure reliable earthing of the ADH NETCOM.

### Montage en rack

Avant et après le montage en rack de l'ADH NETCOM, assurez-vous que le rack est stable. Le montage de l'ADH NETCOM dans un rack doit être tel qu'aucune condition dangereuse ne soit créée en raison d'une charge mécanique inégale. Vérifiez que le débit d'air et la capacité de la source d'alimentation sont disponibles pour l'unité. Assurez-vous que la température de fonctionnement maximale ADH NETCOM de 131 ° F (55 ° C) ne sera pas compromise par d'autres composants du rack. Assurer une mise à la terre fiable de l'ADH NETCOM.

## UNPACKING THE UNIT

Immediately upon receipt, inspect the container and packing material for any noticeable damage. Unpack the ADH NETCOM, taking care not to damage the packing materials. Save the shipping container and related materials until normal operation has been established. If the unit must be returned, take care to ensure that it is repackaged as it was received.

As soon as it arrives at your facility, inspect the ADH NETCOM for electrical and mechanical damage. If any of the following problems are found, contact Environmental Technology, Inc., Customer Service immediately:

- contents incomplete or incorrect;
- internal or external mechanical damage; or
- defective operation.

Environmental Technology, Inc., Customer Service is available between 8:00 a.m. and 5:00 p.m. Eastern Time. In the event of shipping damage, keep the packing materials for inspection by the carrier.

## RETURNS AND REPLACEMENT PART PURCHASES

Prior to removal of equipment for return, please contact Environmental Technology, Inc., Technical Support for troubleshooting assistance.

Before returning an ADH NETCOM to Environmental Technology, Inc., obtain a Return Merchandise Authorization from our Customer Service Department, available between 8:00 a.m. and 5:00 p.m. Eastern Time. If possible, use the original container and packing materials when packing the ADH NETCOM for shipment. It is important to mark the Return Merchandise Authorization clearly on the outside of the shipping container so that it may be correctly processed upon receipt at Environmental Technology.

For more information about replacement parts or for a replacement Data Sheet or Manual, please visit [www.networketi.com](http://www.networketi.com).

## INVENTORY

Using the information below, verify that the shipping package contains all of the parts listed. If there are any discrepancies, notify Environmental Technology, Inc., Customer Service immediately. Customer Service is available between 8:00 a.m. and 5:00 p.m. Eastern Time.

QTY.	PART NO.	DESCRIPTION	TABLE 1. Packing List for ADH NETCOM, AC MODEL.
1	25526	ADH NETCOM Automatic Air Dehydrator AC Power Supply	
1	25546	ADH NETCOM AC Installation Sheet	
1	17618	Power Cord, Euro	
1	18198	1/8" NPT to 1/4" Barbed Brass Fitting	
1	23428	1/8" NPT to 3/8" Barbed Brass Fitting	
1	14513	1/8" NPT to 1/4" Barbed Elbow Brass Fitting	
4	23245	Mounting Bracket	
8	24567	Self-Locking Rack-Mounting Screw (#8-32)	
8	10641	#8 Split Washer	

QTY.	PART NO.	DESCRIPTION	TABLE 2. Packing List for ADH NETCOM, DC MODEL.
1	25527	ADH NETCOM Automatic Air Dehydrator DC Redundant Power Supply	
1	23229	ADH NETCOM Installation Sheet	
1	18198	1/8" NPT to 1/4" Barbed Brass Fitting	
1	23428	1/8" NPT to 3/8" Barbed Brass Fitting	
1	14513	1/8" NPT to 1/4" Barbed Elbow Brass Fitting	
4	23245	Mounting Bracket	
8	24567	Self-Locking Rack-Mounting Screw (#8-32)	
8	10641	#8 Split Washer	

TABLE 3. Packing List for ADH NETCOM NEMA, AC MODEL.

QTY.	PART NO.	DESCRIPTION
1	25523	ADH NETCOM Automatic Air Dehydrator, NEMA AC Power Supply
1	25547	ADH NETCOM NEMA, AC Installation Sheet
1	18198	1/8" NPT to 1/4" Barbed Brass Fitting
1	23428	1/8" NPT to 3/8" Barbed Brass Fitting
1	23571	Bronze Exhaust Muffler (for use as moisture diffuser)

## GLOSSARY

### DUTY CYCLE

The amount of time, expressed as a percentage, that the unit is actually on, cycling, and pumping pressurized dry air.

### HIGH DUTY CYCLE ALARM LEVEL

The configurable set point at which the ADH NETCOM will indicate a high duty cycle. The factory default setting is 50%. The system duty cycle and the discharge pressure are available for display. Typically, the system should be tight enough to limit the duty cycle to less than 20%. System component life decreases as duty cycle increases. A Duty Cycle Alarm occurs if the duty cycle exceeds the configured Duty Cycle Alarm level.

### HIGH LIMIT TARGET PRESSURE

The high set point of the operating pressure range for the dehydrator. This is the pressure setting which the unit will target during compressor operation. The actual turn-off pressure is adjusted in the software every pressurization cycle after determining the rate of pressure change during that cycle. This software compensation for the rate of pressure change during pressurization minimizes compressor "undershoot." The High Limit Target Pressure must be between 0.20 psig and 7.5 psig (14mbar to 517mbar). The factory default setting for High Limit Target Pressure is 0.5 psig (34.5mbar).

### HIGH PRESSURE ALARM LEVEL

The user-configurable high pressure limit at which an alarm condition will be indicated. Note that the High Pressure Alarm Level must be set higher than the High Limit Target Pressure setting. The factory default setting is 1.5 psig (103.5mbar). A High Pressure Alarm occurs if the pressure exceeds the configured High Pressure Alarm Level for more than 30 seconds. Mechanical Overpressure protection is recommended within the system to prevent pressure reaching the High Pressure Alarm level.

### LOW LIMIT TARGET PRESSURE

The low set point of the operating pressure range for the dehydrator. This is the pressure setting at which the unit will turn off the compressor during compressor operation. The Low Limit Target Pressure must be set lower than the High Limit Target Pressure by at least 0.1 psig (7mbar). The factory default Low Limit Target Pressure is 0.30 psig (21mbar).

### LOW PRESSURE ALARM LEVEL

The user-configurable low pressure limit at which an alarm condition will be indicated. Note that the Low Pressure Alarm Level setting must be set lower than the Low Limit Target Pressure setting, and that the factory default setting

is 0.15 psig (10mbar). A Low Pressure Alarm occurs if the pressure stays below the configured Low Pressure Alarm Level for more than 30 seconds.

### **SOLAR GAIN**

Generally occurring each day at sunrise, the time when sunlight and heat increase, resulting in a natural corresponding rise in temperature and pressure inside a cable line. Solar gain can also occur before or after a major weather effect.

### **VSWR**

VSWR means Voltage Standing Wave Ratio and is used to measure the amount of energy that is reflected back into the transmitter from the antenna when the antenna is not tuned properly. Water in the transmission line will de-tune the antenna and cause a higher VSWR.

## **PRODUCT FEATURES**

Major features of the ADH NETCOM automatic air dehydrator are listed below. Refer to Figures 1 and 2 for schematic drawings of the ADH NETCOM AC and DC unit configurations.

The ADH NETCOM is functionally equivalent to the earlier ADH-2ACOM and the ADH-3COM automatic air dehydrators with regards to basic mechanical features such as air drying and pressurization. The ADH NETCOM automatic

air dehydrator offers improved network communications, extended product life expectancy, and simplified ordering and installation. Product features include:

- A drop-in replacement for previous ADH models currently in service
- Similar specifications to earlier ADH models
- Indoor and outdoor mounting options
- 100 to 240 VAC and +/- 20 to 75 VDC power options
- All operational parameters can be easily set by simple web interface
- Communications interfaces include Ethernet networking, RS-422/485, and RS-232
- Network communication protocols include HTTP, SNMP, UDP, and Scientific-Atlanta (S-A)
- Master/slave functionality for automatic operations of paralleled dehydrators
- Interface for the ASM-1 Smart Manifold for automatic operation of one or more antennas from one or more dehydrators
- Complete set of programmable alarms, including three user-configurable alarm relays
- Software can be updated remotely through the network interface, permitting performance updates throughout the life of the dehydrator

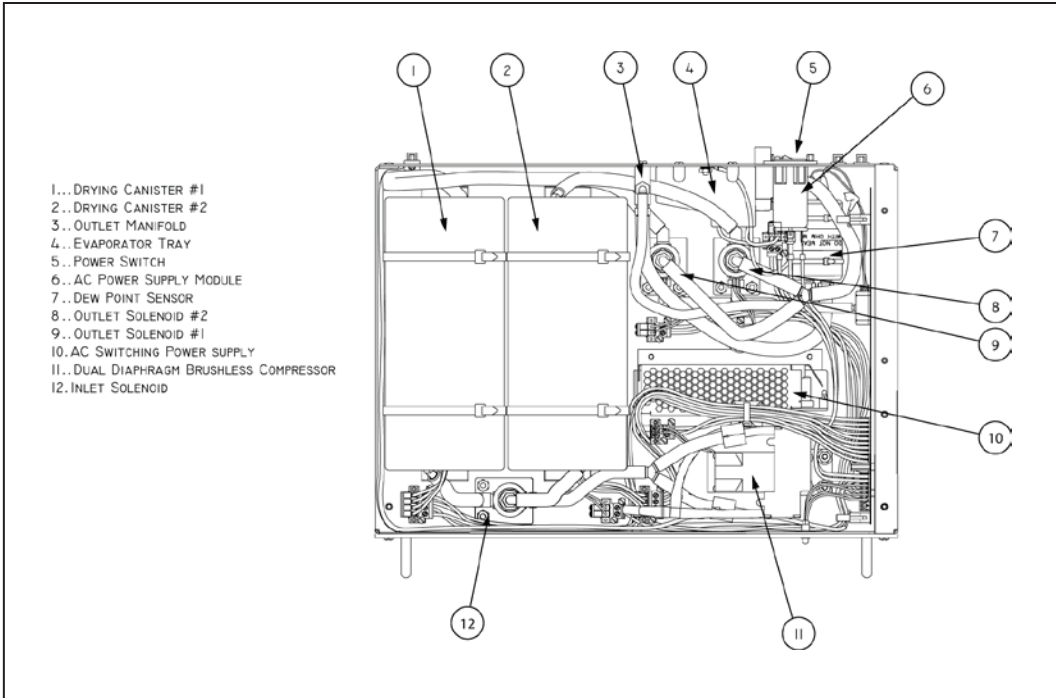

FIGURE 1. ADH NETCOM AC Unit Components.

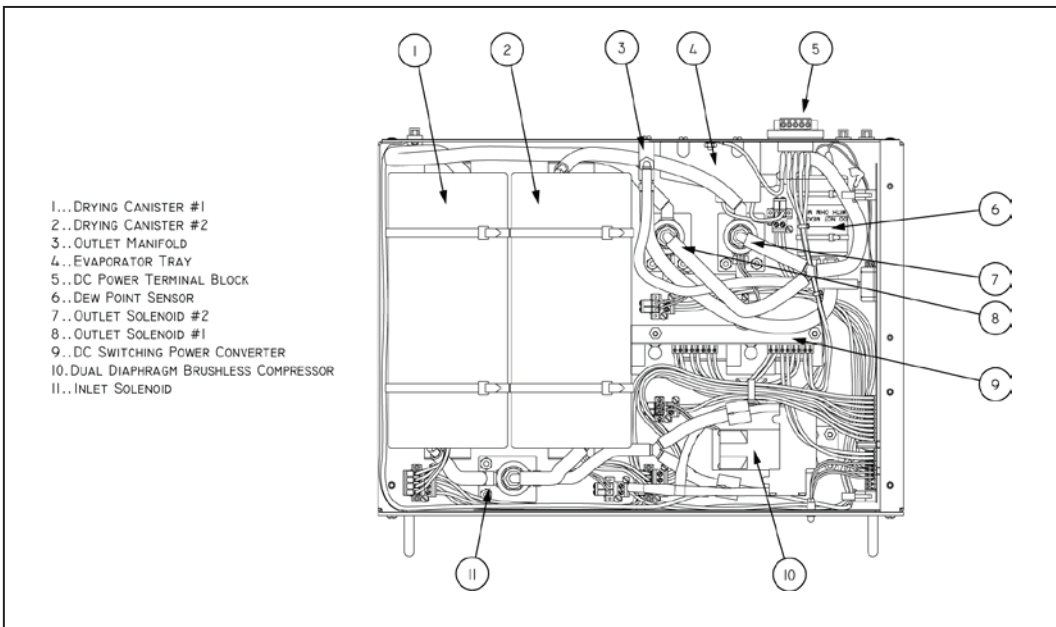

FIGURE 1. ADH NETCOM DC Unit Components.

## ADH NETCOM AUTOMATIC AIR DEHYDRATOR MEAN TIME BETWEEN FAILURE RELIABILITY STATEMENT

Environmental Technology, Inc., hereby confirms that all original components and spare or replacement parts used in the ADH NETCOM Automatic Air Dehydrator have the reliability characteristics stated below. The ADH NETCOM meets or exceeds our previous generation of automatic air dehydrators in all aspects of fit, form, and function.

ADH NETCOM - Overall Reliability Mean Time Between Failure (MTBF) Rate: More than 75,000 hours when maintaining a 5% or lower duty cycle.

### ADH NETCOM AUTOMATIC AIR DEHYDRATOR ORIGINAL COMPONENT AND REPLACEMENT PART RELIABILITY LIST

PART DESCRIPTION	COMPONENT PART NUMBER	REPLACEMENT KIT PART NUMBER	MTBF (HOURS)	STORAGE (°C)
Main Circuit Board	23253	24084	75,000+	-40 to +60
Compressor Assembly	23216	24085	160,000+	-40 to +60
Absorption Unit (Air Drying Canister)	23218	24054	96,000+	-40 to +60
Power Filter Module and Switch (AC)	23446	24086	458,900+	-40 to +60
Power Filter Module (NEMA)	23563	24087	458,900+	-40 to +60
Discharge Manifold with safety relief valve	23173	24088	100,000+	-40 to +60
Solenoid, Outlet	23214	24090	150,000+	-40 to +60
Solenoid, Inlet	23270	24096	150,000+	-40 to +60
Humidity Sensor Assembly	23368	24091	75,000+	-40 to +60
Humidity Sensor Assembly (NEMA)	23707	24092	75,000+	-40 to +60
ADH NETCOM Manual	23526	(23526)	-	-
AC Power Supply Module	23450	24094	420,500+	-40 to +60
AC Power Supply Module (NEMA)	23566	24093	420,500+	-40 to +60
DC Dual Redundant Power Supply Module	23224	24095	100,000+	-40 to +60



## DESCRIPTION AND THEORY OF OPERATION

A detailed product description and theory of operation for the ADH NETCOM automatic air dehydrator are presented below.

### FUNCTION

Unpressurized transmission lines allow the entry of moist ambient air through leaking seals and cracks. When the line passes from one environment to another (such as entering a shelter from the antenna outside) or when there is a change in existing environmental conditions (such as a weather front or nightfall) the pressure and/or temperature changes in the air will result in the collection of water inside the line. This is normally the result of the ambient temperature dropping below the dew point. Water in transmission lines causes corrosion, voltage arcing, and increased VSWR, all of which reduce system performance.

The ADH NETCOM automatic air dehydrator prevents the accumulation of moisture in transmission lines by maintaining the pressure and dew point of the air inside the line. Supplying low pressure dry air, the ADH NETCOM keeps waveguides, air-dielectric coaxial cable and related components used in earth station and terrestrial UHF and microwave communication systems dry.

### PRINCIPAL CONSIDERATIONS

The ADH NETCOM works best supplying dry air in a flowing system, where the dehydrator completely replaces the air on a regular basis. Consequently, the equipment being supplied dry air should have a bleed system. For a waveguide, this is best accomplished by slightly opening a purge valve at the window end of the system. Installing a pressure relief valve, purposely set higher than the High Limit Target Pressure, will allow the solar pressure gain to bleed off. This will provide for greater system stability and repetitive daily performance and results. Likewise, air dielectric coaxial cable should be equipped with a valve at the far end which can be set to allow a small continuous bleed. Many systems will have sufficient normal leakage

that such actions might not be necessary. For optimal performance and life expectancy of the dehydrator a duty cycle between 1% and 10% is recommended.

The ADH NETCOM has check valves in the air path and a pressure relief valve. A tightly sealed system may experience a pressure increase with a rise in ambient temperature. The ADH NETCOM will relieve such build-up should it reach 8 psig (552mbar) but it is advised the ADH NETCOM not be used as the only means of overpressure protection.

### DEHYDRATION SYSTEM

The ADH NETCOM is a low pressure automatic air dehydrator. Low pressure air provides personnel and equipment safety along with energy efficiency. Activated alumina is used as the drying agent. Alumina, or aluminum oxide, is an energy efficient desiccant with a long life expectancy.

Air is dehydrated by passing it through a drying canister containing the drying agent. The dried air is delivered to the communications equipment through a connection in the rear panel. The moisture is removed from the drying canisters by heat. The default configuration provides dry air at 0.5 psig (34.5mbar) and is capable of delivering 26 cubic feet of air per hour (12.3 liters per minute).

Two drying canisters provide a continuous supply of dry air. One unit is active while the other is maintained in stand-by or being regenerated. The ADH NETCOM will operate on one of the canisters until the canister is wet enough to trip the dew point sensor. When this occurs, the stand-by drying canister is brought into service and the used unit is regenerated. The drying canister being regenerated is heated internally with a resistance heater until a temperature is attained which will convert all absorbed water into steam. The resulting vapor is purged by pumping ambient air through the drying canister and collecting the water in an evaporator where it is again heated and driven off as water vapor. No drain line or special ventilation is needed with standard units. On ADH NETCOM NEMA units, the purge air and steam is evacuated out of the enclosure either by

using the bronze muffler (supplied), which serves as a moisture diffuser, or through a customer-supplied drain line via the 1/8" NPT discharge fitting, eliminating moisture from inside the weather-tight enclosure.

## PRESSURIZATION

The dual-diaphragm compressor features a brushless motor. It provides a flow rate of 26 scfh (12.3 l/m). The discharge pressure cycles between two limits. These limits are user-configurable in a range between 0.10 psig and 7.50 psig (7mbar - 517mbar) in 0.01 psig (1mbar) increments. Additional information regarding user-configurable settings is provided later in this manual. A safety relief valve operates at 8 psig (552mbar) to provide over-pressure protection.

A solid state pressure transducer senses discharge pressure. The transducer's signal is digitized and processed to control the compressor. The compressor comes on when the pressure falls below the Minimum Pressure and shuts off at the Maximum Pressure.

A High Pressure Alarm occurs if the pressure exceeds the

configured High Pressure Alarm level for more than 30 seconds. The factory default High Pressure Alarm level is 1.5 psig (103.5mbar). A mechanical pressure safety relief valve provides over pressure protection independent of the electronic system. The set point of the safety relief valve is 8 psig (552mbar).

The compressor duty cycle and the discharge pressure are available over the Ethernet or communications ports. Typically, the system should be tight enough to limit the duty cycle to less than 20%. Dehydrator life decreases as duty cycle increases. A Duty Cycle Alarm occurs if the duty cycle exceeds the configured Duty Cycle Alarm level. The factory default Duty Cycle Alarm level is 50%.

## DISPLAYS

Standard display configuration includes two LED indicators on the front panel for POWER and ALARM. Refer to Figure 3. A web interface provides detailed status information display and allows for unit configuration.

### NOTE:

If the temperature in the ADH NETCOM automatic air dehydrator is measured at less than 32°F (0°C), the dehydrator will not turn the compressor on. For NEMA units, an enclosure heater will be energized any time the temperature in the dehydrator is below 40°F (4.4°C).



FIGURE 3. The ADH NETCOM Front Panel.

## COMMUNICATIONS

The ADH NETCOM automatic air dehydrator includes support for both Ethernet network communications and legacy serial communications. The Ethernet capabilities within the ADH NETCOM include support for the web interface, Simple Network Management Protocol (SNMP), User Datagram Protocol (UDP) and Trivial File Transfer Protocol (TFTP). It allows for monitoring and configuration of the dehydrator as well as providing a means for upgrading the dehydrator's software in the field.

The serial capabilities within the ADH NETCOM include legacy support for the Scientific-Atlanta (S-A) protocol used in previous ADH dehydrators. Both RS-422/485 and RS-232 ports are provided for the greatest degree of flexibility.

The ADH NETCOM automatic dehydrator includes three alarm relays for communicating alarm conditions. These are configured at the factory for SUMMARY ALARM, LOW PRESSURE ALARM, and DEW POINT ALARM, but each alarm relay can be user-programmed to any of the alarm conditions tracked by the ADH NETCOM. Each relay has one contact which closes on an alarm condition or loss of power and one contact which opens under the same circumstances. Refer to Table 6 on page 30 of this manual for more information.

### SUPPLY POWER

The ADH NETCOM automatic dehydrator is available in both AC and DC supply power models. AC units have a switching power supply that operates from 100 to 240 VAC, 50/60Hz. DC units have a switching power converter that operates from 20 to 75 VDC with a positive or negative ground system. Neither the AC nor DC units require any customer adjustments to operate within the allowed supply power ranges.

### CANISTER REGENERATION

Drying canister regeneration is controlled by the microprocessor. A thermocouple monitors the temperature of the drying canister. The drying canister

is heated until the desired temperature is reached. The drying canister and its contents are allowed to soak at this temperature for approximately two and one-half hours. The drying canister is then purged by pressurized air into the internal evaporator tray, eliminating the need for a drain line.

If the drying canister fails to reach the desired temperature, it is declared dead and an error is issued. The drying canister is allowed six (6) hours to cool. If it fails to cool to less than 18°F (10°C) above the ambient temperature, the unit is declared dead and an error is issued.

### CONDITIONS FOR REGENERATION

The ADH NETCOM automatic dehydrator has two conditions that will mark a drying canister for regeneration: moisture or time.

During normal operation, regeneration begins when the dew point sensor determines that the discharge air from the canister is "wet." A "wet" condition means a dew point higher than -25°F (-31.7°C), which is still extremely dry air. The amount of time that a drying canister is in service is recorded by the ADH NETCOM. As a precaution, if a drying canister stays in service for 200 hours, the ADH NETCOM will place that canister into regeneration even though sensed moisture has not reached levels that would be considered wet. This ensures that the drying agent is periodically regenerated even in low dew point conditions to extend the life of the drying agent and ensure peak operation of the dehydrator.

When power is initially applied to the unit, operation begins with the use of one drying canister. The discharge air is monitored for moisture for a short time. The first drying canister is taken out of service and the other drying canister is brought into service. If the first drying canister was determined to be wet, it is placed in a regeneration cycle; otherwise, it is placed in stand-by. The second absorption canister is also tested. If the second drying canister is found to be wet, the first drying canister is brought back into use and the second drying

canister is regenerated. The normal regeneration cycle is then entered. If both drying canisters are found to be wet, the drying canister remains in service while the first is regenerated and the dew point alarm is issued.

## SENSORS

The ADH NETCOM automatic air dehydrator has five internal sensors. There are three temperature sensors: the ambient air temperature sensor on the control board, as well as a temperature sensor on the housing of each of the two drying canisters. A fourth sensor, located on the control board, measures the discharge air pressure. The fifth, a dew point sensor, measures the moisture levels in the discharge air.

## CONTROL BOARD

The ADH NETCOM utilizes a single control board which includes the microprocessor, the pressure sensor, and I/O connections for both internal control and external communications. The microprocessor controls all internal dehydrator functions. It acts on data collected from various sensors to control operation of the compressor, absorption canister heaters, and solenoid valves. It monitors system operation and generates status and alarm conditions which are communicated via LED indicators (power and summary alarm), programmable alarm relays, serial I/O interfaces (RS-422/485 and RS-232), and through the communications module. The

communications module is a plug-in board that controls Ethernet networking including SNMP, the web interface, UDP, and TFTP. The control board includes the pressure sensor and the ambient temperature sensor.

## MACHINE PREPARATION AND SET-UP

Before installing the unit as desired for your site, it is first necessary to connect the proper fitting and air line, as well as the power and desired communications cable(s), on the back panel of the machine.

When connecting an equipment or transmission line to the ADH NETCOM automatic air dehydrator, it is first necessary to install the proper fitting onto the port on the back of the unit. Refer to Figure 4. As described on the Inventory page of this manual, two types of brass fittings are supplied with the unit. They are not interchangeable. The first type, Part Number 18198, connects a 1/8" NPT to a 1/4" barbed fitting. The second type of fitting, Part Number 23428, connects a 1/8" NPT to a 3/8" barbed fitting. Though not required, it is recommended to use the second type of fitting, the one with the 3/8" barbed fitting, on runs longer than one hundred (100) feet or about 30 meters or when using the NETCOM as an input to an ASM®-1 Smart Manifold™ Automated Air Distribution Manifold. Directions for the proper installation of both types of fittings are the same.

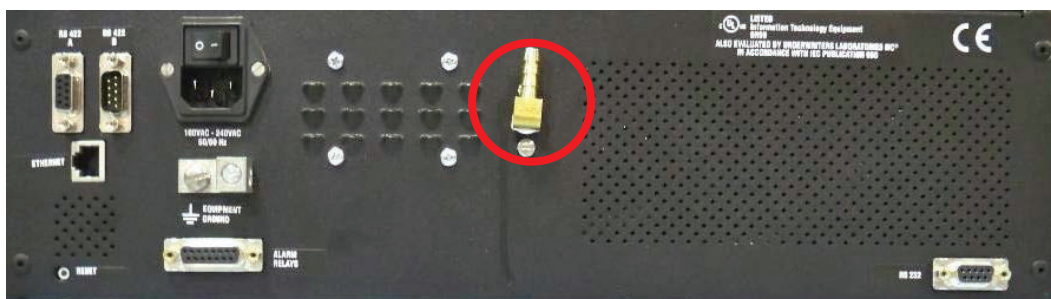

FIGURE 4. ADH NETCOM Rear Panel (with fitting installed).

1. Before installing the fitting onto the back of the dehydrator, first apply some Teflon® thread tape (or compatible thread sealant) around the threads of the fitting you will be using. Refer to Figure 5.

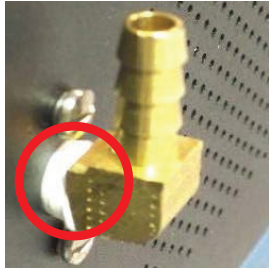

FIGURE 5. Thread Tape on Fitting.

2. Install the fitting into the port on the back of the unit. Finger-tighten the fitting into the port. Using a wrench, fully tighten the fitting onto the port. Carefully rotate the fitting with the wrench at least two more turns to the right or clockwise until fully tightened into the back of the unit.

3. Once the brass fitting has been properly installed onto the ADH NETCOM port, secure the air hose in place on the fitting by pressing the hose tightly onto the fitting.
4. Connect the other end of the hose into the fitting on the waveguide flange or the component to be pressurized with dry air.
5. Prior to connecting the unit power cable, first ground the chassis by connecting the ground lead to the Equipment Ground terminal on the back of the unit. Refer to Figure 6. The three-prong power cable (on AC units) also provides ground protection, but this connection provides redundant ground protection for increased safety.
6. For AC units, after connecting the ground wire, make sure that the unit power switch is in the OFF or "O" position, then plug in the power cable to a surge protecting electrical outlet power strip. Leave the power switch in the OFF position. On DC units, there is no power switch so the unit is functional as soon as the DC power cable is connected. Refer to Figure 7.

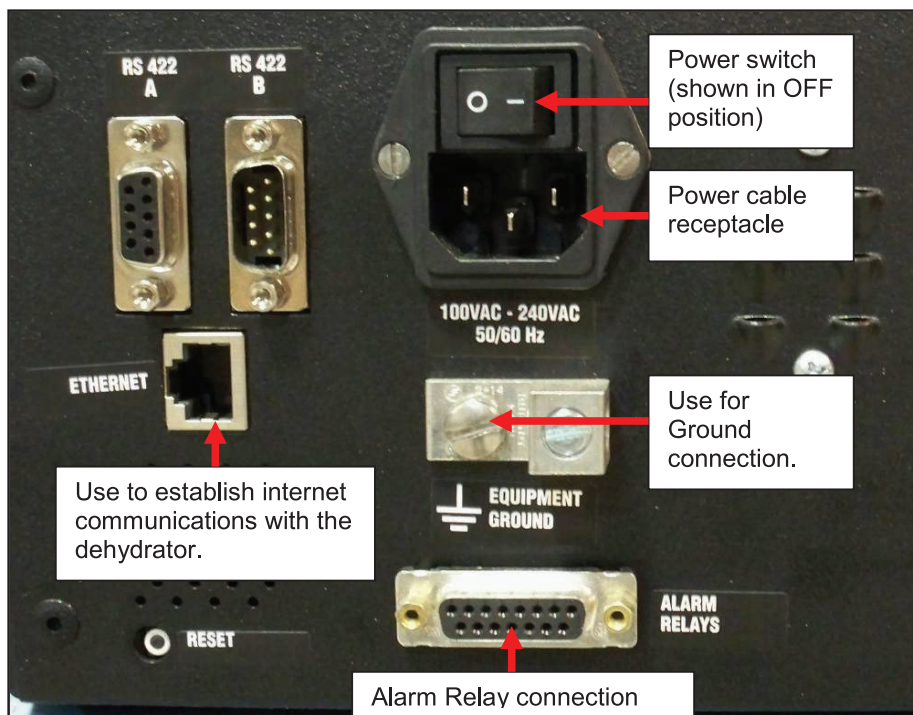

FIGURE 6. ADH NETCOM AC Version Rear Panel Detail.

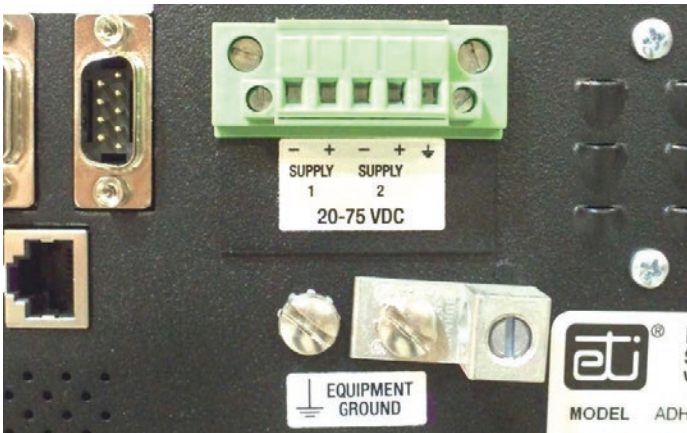

FIGURE 7. ADH NETCOM DC Rear Panel Detail.

### CONFIGURING TWO DEHYDRATORS AS MASTER / SLAVE

In the Configuring The System section in this manual, instructions will be given on configuring two dehydrators to function with each other as master and slave. To be set up as master and slave, it is not necessary for two dehydrators to be physically connected to each other during the configuration process. However, they must be physically connected to each other following configuration in order to be able to function as master and slave to each other.

Although the Ethernet cable is the preferred means of connecting two dehydrators, if you are trying to establish communications between a new dehydrator and an existing one, or to configure a new dehydrator to function with an existing unit, use the RS-422A/B ports between units to make that connection.

If using the Ethernet connection, typically, both units will need to be on the same network. However, if they are not, a cross-over cable must be used between the two dehydrators. In the Serial Port Configuration box, use the pull-down menu to establish that connection, referring to the Help screens that appear when the cursor is placed in that field.

## INSTALLATION

The ADH NETCOM automatic air dehydrator can be rack mounted or mounted to a wall. Refer to Figure 8, as well as the information below.

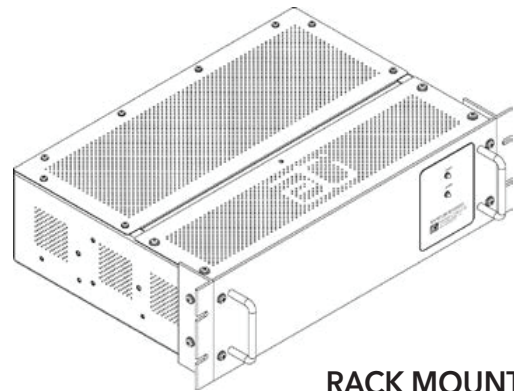

**RACK MOUNT**

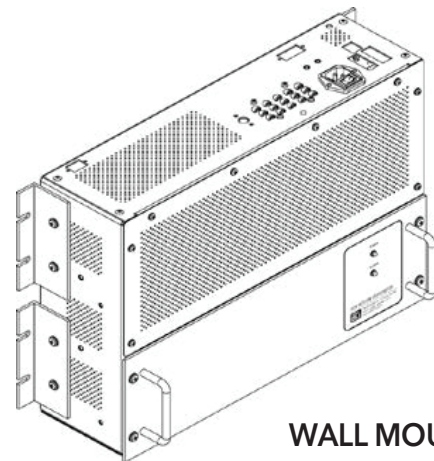

**WALL MOUNT**

FIGURE 8. A standard ADH NETCOM configured for Rack Mount or Wall Mount installation

To configure the dehydrator for wall mount installation, remove the front panel and the portion of the vented cover with the ETI logo, then re-install each where the other had been. Reinstall the front panel so that it will be in the new front position once the dehydrator is oriented for wall mounting. Reinstall the small vented panel so that it will be in the new bottom position. Refer to Figure 9.

Unit comes ready for rack mount installation.

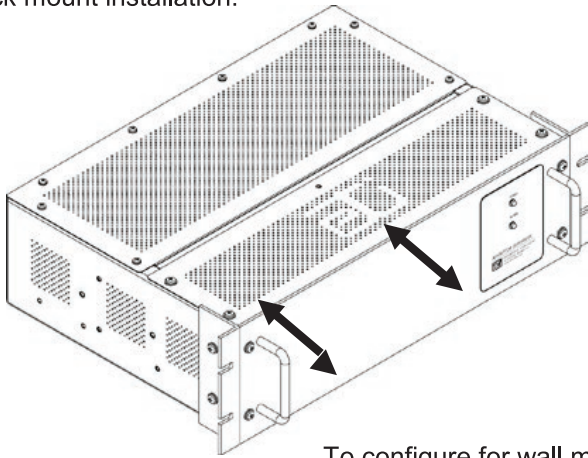

To configure for wall mount installation, remove and switch panels as shown.

FIGURE 9. Switching panels for installation.

### RACK MOUNTING

The ADH NETCOM automatic air dehydrator can be mounted in a standard 19" communications rack at one of four depths utilizing two mounting locations. Mounting depths available are flush, 2", 6", and 8". Refer to Figures 10 through 16. The side panels of the chassis contain tapped holes (#8-32) to facilitate installation. The ADH NETCOM automatic dehydrator should be mounted using chassis slide rails (not supplied) or on support channels mounted on the inside of the relay rack. Because the ADH NETCOM seldom requires operator attention, a location in the lower portion or extreme upper portion of the rack may be considered.

### CAUTION

Before and after rack mounting the ADH NETCOM, ensure that the rack is stable. Mounting of the unit into the rack should be such that a hazardous condition is not created due to uneven mechanical loading. Verify that adequate air flow and power supply capacity is available to the unit. Ensure that the maximum operating temperature of 130°F (55°C) will not be compromised by other components in the rack. Ensure reliable earthing of the ADH NETCOM.

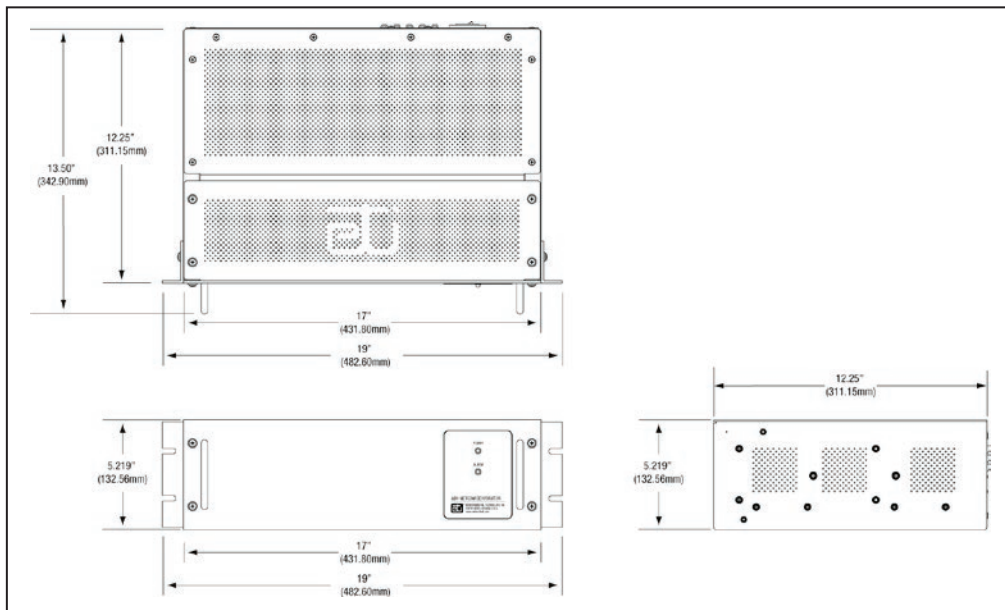

FIGURE 10. ADH NETCOM Rack Mount dimensions.

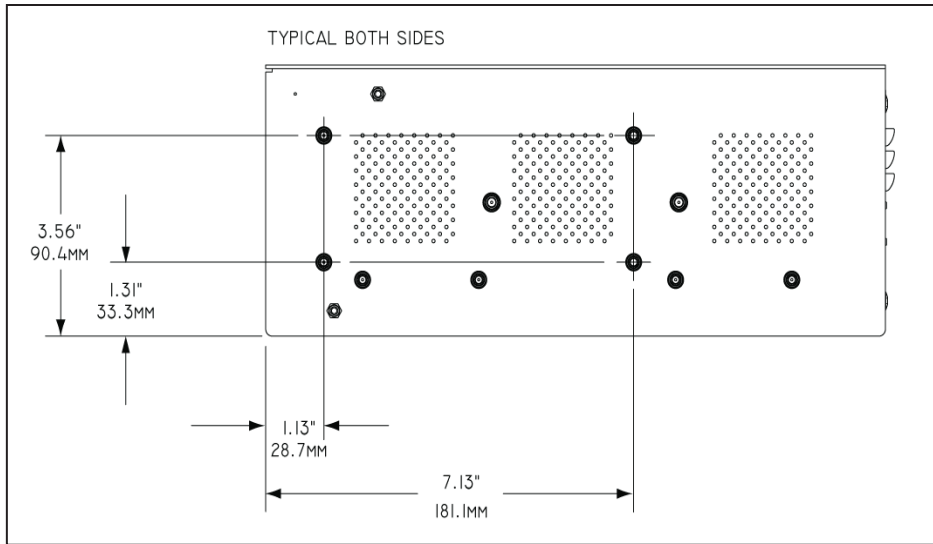

FIGURE 11. ADH NETCOM Rack Mount Hole Dimensions.

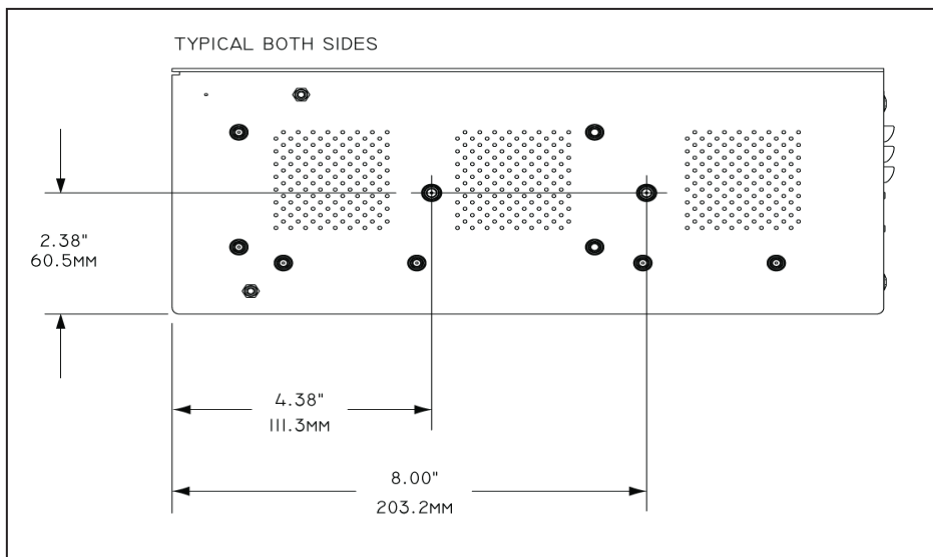

FIGURE 12. ADH NETCOM Slide Rail Mount Hole Dimensions.



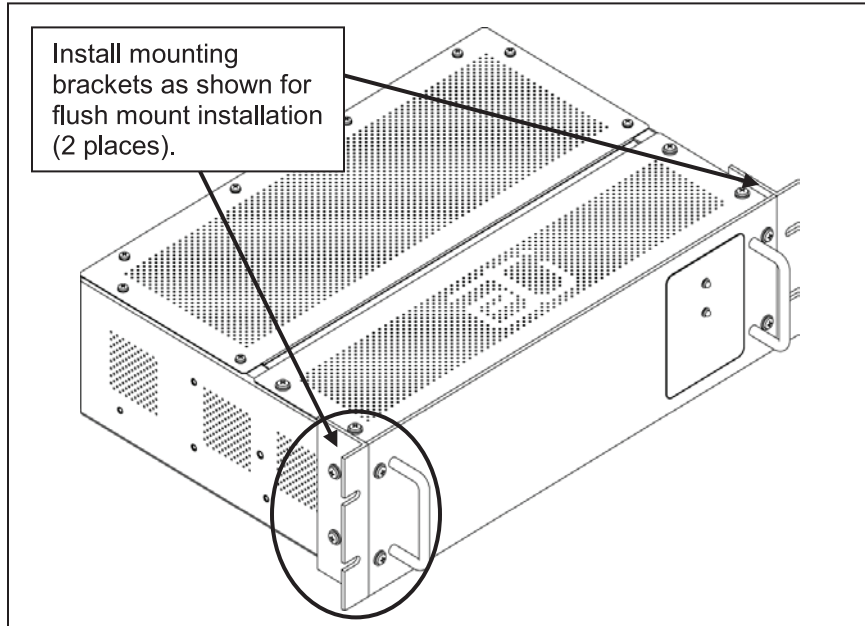

FIGURE 13. Mounting brackets in flush mount position.

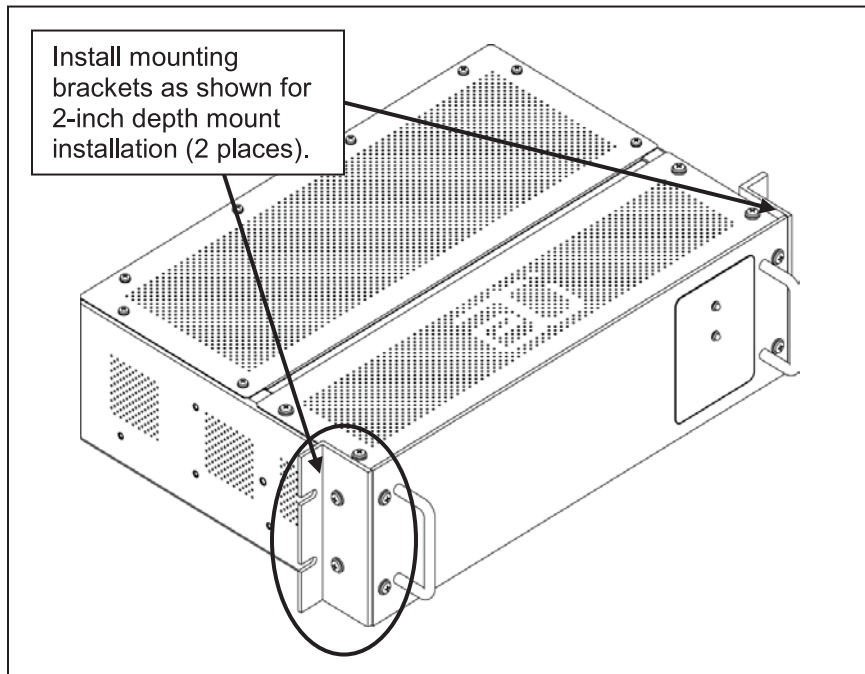

FIGURE 14. Mounting brackets in 2-inch depth position.

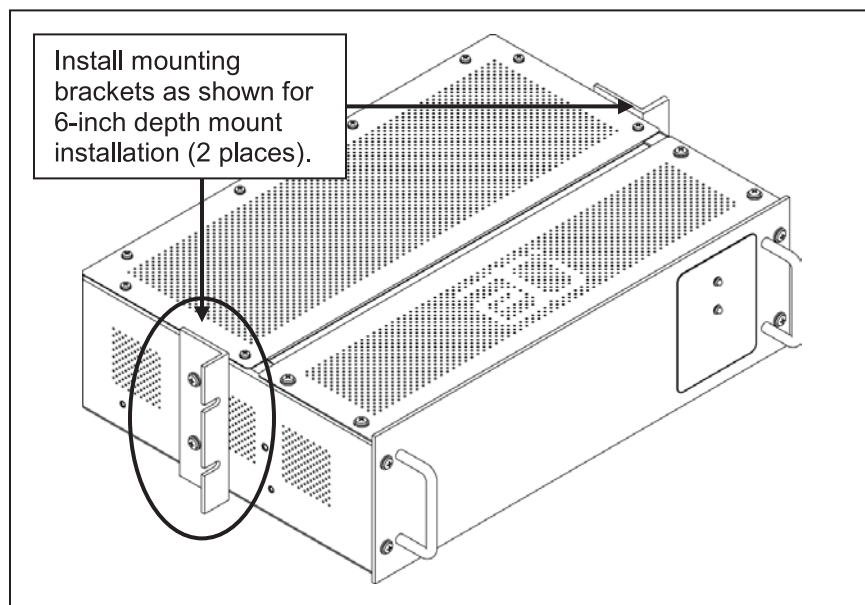

FIGURE 115. Mounting brackets in 6-inch depth position.

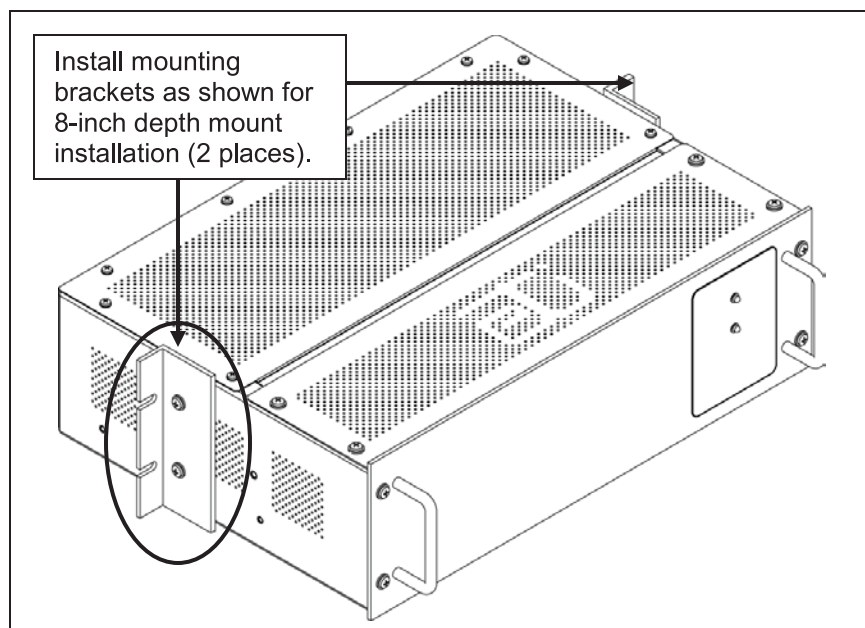

FIGURE 16. Mounting brackets in 8-inch depth position.

## WALL MOUNTING

Wall mounting an ADH NETCOM requires an area approximately 17" high by 19" wide, and will project a little more than 6" out from the wall. Refer to Figure 17. Plan your installation so that the ADH NETCOM will not interfere with normal traffic patterns at your site. Ensure that the wall mounted unit has sufficient clearance above the connection panel to facilitate access to the power, communications, and pneumatic interfaces.

To wall mount an ADH NETCOM automatic air dehydrator, all four mounting brackets are used. Refer to Figures 18 and 19. The mounting brackets will accommodate fasteners up to 1/4" (6mm) in diameter. The choice of anchors and companion hardware should be appropriate for the mounting surface. At least four anchors (minimum one per mounting bracket) should be used and each should be capable of supporting at least 16 pounds (7.3 kg). If more than four anchors are used, it is recommended that the combined load capacity be at least 64 pounds (29 kg).

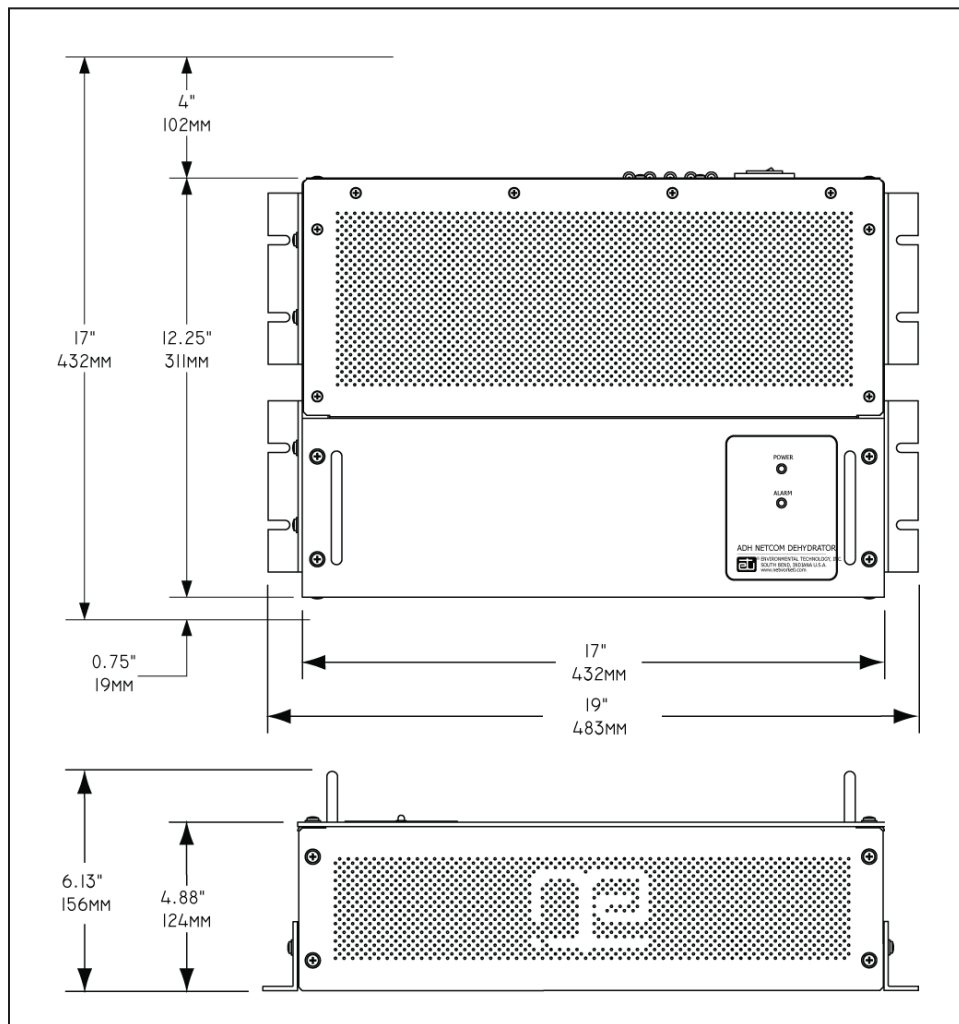

FIGURE 17. Wall mount dimensions.

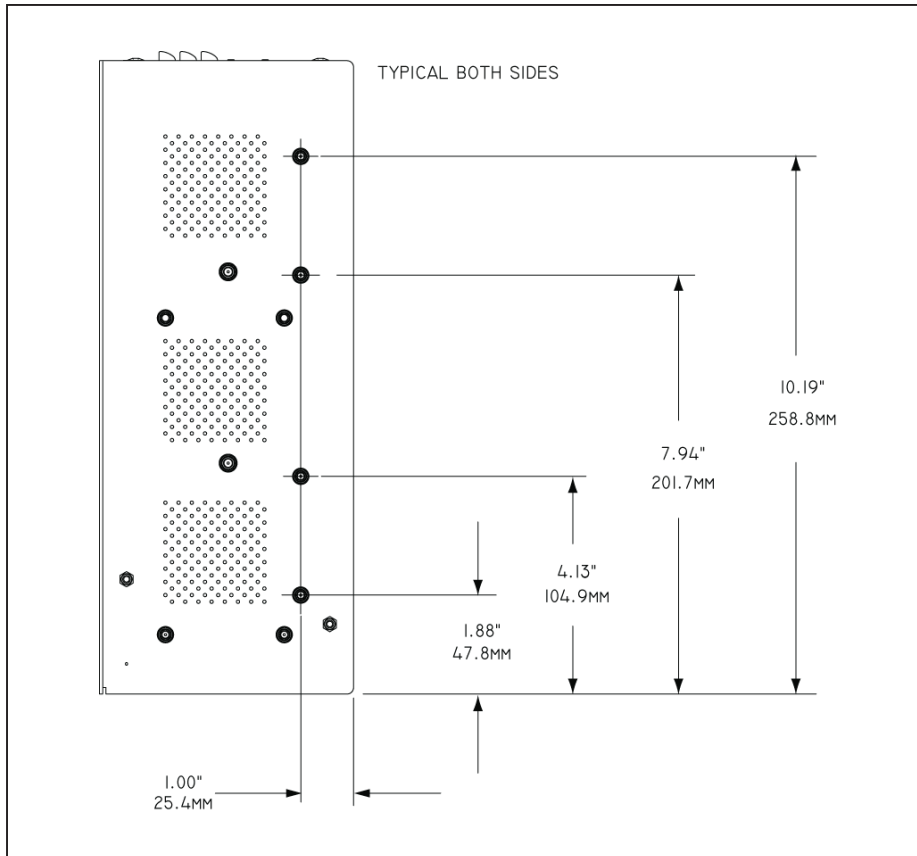

FIGURE 18. Wall mount bracket hole dimensions.

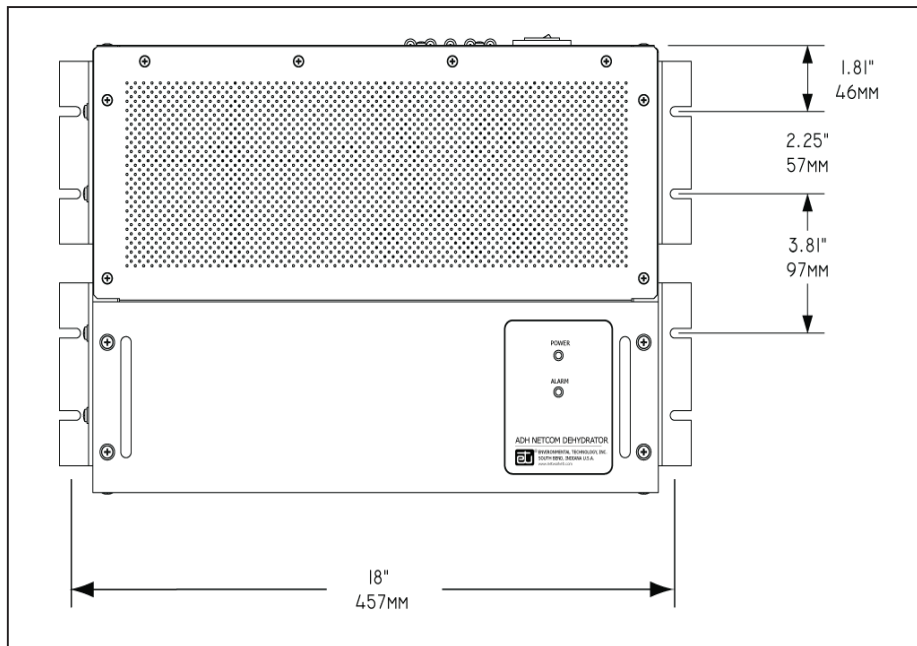

FIGURE 19. Wall mount point dimensions.

## COMPUTER NETWORK COMMUNICATIONS

The ADH NETCOM automatic air dehydrator features Ethernet network communications, as well as RS-232 and RS-422/485 serial communications. The primary protocols utilized by the Ethernet communications are SNMP (Simple Network Management Protocol), HTTP (Hypertext Transfer Protocol), UDP (User Datagram Protocol), and TFTP (Trivial File Transfer Protocol). ADH NETCOM communications capabilities allow for monitoring and configuration of the unit, as well as providing a means for upgrading the software in the field.

The ADH NETCOM Ethernet communications run at 10Base-T data rate and half duplex. It is recommended that the network interface to the ADH NETCOM is manually set to these parameters and NOT to an auto-configuration mode.

The ADH NETCOM includes three alarm relays for external indication of alarm conditions. These are configured at the factory as Summary Alarm, Low Pressure Alarm, and Dew Point Alarm, although each relay can be customer programmed to any of the alarm conditions tracked by the unit.

The ADH NETCOM serial ports use standard DB-9 connectors. Pin outs for the RS-232 are shown in Table 4 below and for the RS-422/485 in Table 5. The Ethernet port uses a standard RJ-45 connector and can use CAT-5 or CAT-5E UTP cable. The alarm relays use a female DB-15 using the pin outs as shown in Table 6.

PIN	DESCRIPTION
1	OPEN
2	TX
3	RX
4	DTR
5	GND
6	DSR
7	CTS (Tied to Pin 8)
8	RTS (Tied to Pin 7)
9	OPEN

**NOTE:** Use straight cable to PC.

TABLE 4. RS-232 Pin descriptions.

PIN	DESCRIPTION	COMMENTS
1	Shield Ground	
2	Receive Ready	Tied internally to +5 volts via a 4.7K resistor
3	Receive +	Also typically referred to as "R+" or "RB"
4	Transmit +	Also typically referred to as "T+" or "TB"
5	Signal Ground	
6	Transmit -	Also typically referred to as "T-" or "TA"
7	Ready To Send	Pin 7 (RTS) is tied internally to Pin 8 (CTS)
8	Clear To Send	Pin 8 (CTS) is tied internally to Pin 7 (RTS)
9	Receive -	Also typically referred to as "R-" or "RA"

TABLE 5. RS-422 Pin descriptions.

PIN	DESCRIPTION
1	RELAY 1 Closed on alarm
2	RELAY 1 Open on alarm
3	RELAY 2 Closed on alarm
4	RELAY 2 Common
5	RELAY 2 Open on alarm
6	Not used
7	Not used
8	Not used
9	RELAY 1 Common
10	RELAY 3 Common
11	RELAY 3 Open on alarm
12	RELAY 3 Closed on alarm
13	Not used
14	Not used
15	Not used

TABLE 6. DB-15 Pin descriptions.

For additional information regarding ADH NETCOM automatic air dehydrator computer communications, refer to Appendix B in this Manual, Communication Protocols, and Appendix C, Master Configuration Appendix.

## CONFIGURING THE SYSTEM

### USER SETTINGS

The ADH NETCOM automatic air dehydrator allows for user configuration of many of its operational parameters. User-configurable alarm settings, along with their default values, are explained in the Alarms section of this Manual.

The ADH NETCOM automatic air dehydrator can be configured and monitored using the simple web interface. Initial set-up is typically done with a standalone PC or laptop computer configured for use in the 192.168.52.0 network. A typical IP address for the configuring host would be 192.168.52.1, with a subnet mask of 255.255.255.0. The initial factory default setting for the ADH NETCOM is a fixed IP address of 192.168.52.9, a fixed subnet mask of 255.255.255.0, and a fixed gateway of 192.168.52.1. Open a web browser and connect to this IP address. Pictured below in Figure 20 is the Status Screen, which is the default screen.

From the Status Screen, the Configuration page allows users to configure high and low pressure limits and alarms, establish master/slave designations between dehydrator units, set duty cycle and short cycle limits, as well as define the three alarm relays. Also on the Configuration page the user can configure the serial ports on the back of the unit. There are three ports, for RS422A, RS422B, and RS232, on the back of the dehydrator and each can be configured. See unit Manual for more information regarding the use of the Scientific-Atlanta protocol.

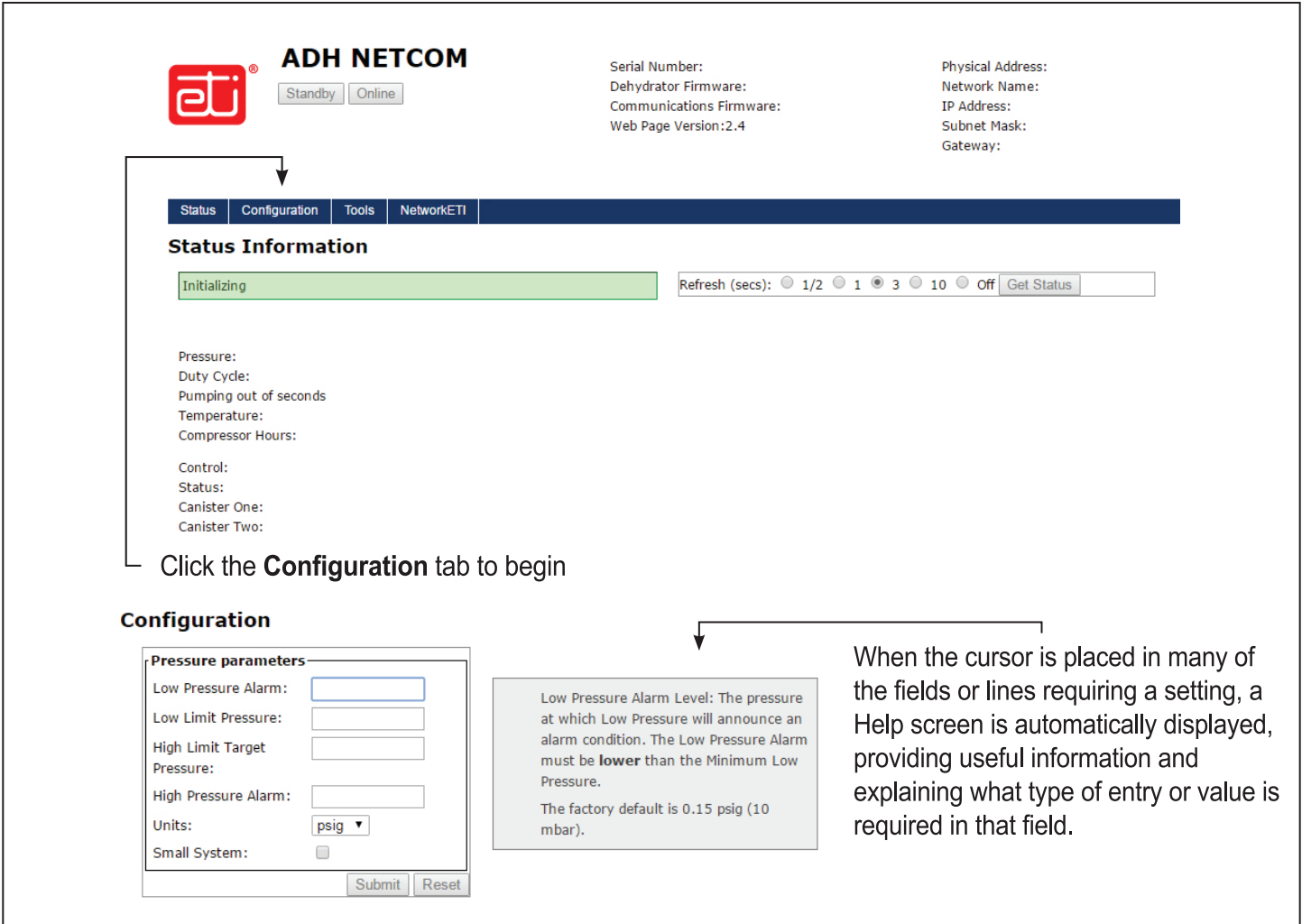

FIGURE 20. Status Screen

## COMMUNICATING WITH THE DEHYDRATOR

Your IT (Information Technology) Department is the best source of information if you encounter problems or difficulties in connecting to or communicating with the dehydrator.

The factory default ethernet communication setting is a fixed IP address of 192.168.52.9, a fixed subnet mask of 255.255.255.0, and a fixed gateway of 192.168.52.1. To Connect.

1. Temporarily assign computer an IP address in the 192.168.52.0 network range, typically 192.168.52.1, with the subnet 255.255.255.0. Note the original configuration so you can restore it when done.
2. Open network connection using web browser via Ethernet connection. If easily available, a cross-over cable or switch is recommended, though a normal Ethernet cable will work fine in most cases.
3. Connect to 192.168.52.9.

## PRESSURE PARAMETERS

1. Connect to the dehydrator. Go to the Configurations page. Locate the Pressure Parameters field. See Figure 21.
2. Using the Units pull-down selector, select USC (psig) or SI (mbar) units.
3. To change the current operational pressure settings, enter the desired values in the appropriate fields:
  - Low Pressure Alarm - The pressure at which low pressure will cause an alarm condition.
  - Low Limit Target Pressure - The low set point at which the unit will start pumping.
  - High Limit Target Pressure - The high set point at which the unit will stop pumping.
  - High Pressure Alarm - The pressure at which high pressure will cause an alarm condition.
4. Small System uses one of the two drying canisters as an additional pressure reservoir. This generally would be used on systems with a total volume of less than 1/2 cubic foot. Select this option, if appropriate, by checking the box.
5. Click the Submit button for the settings indicated to take effect.

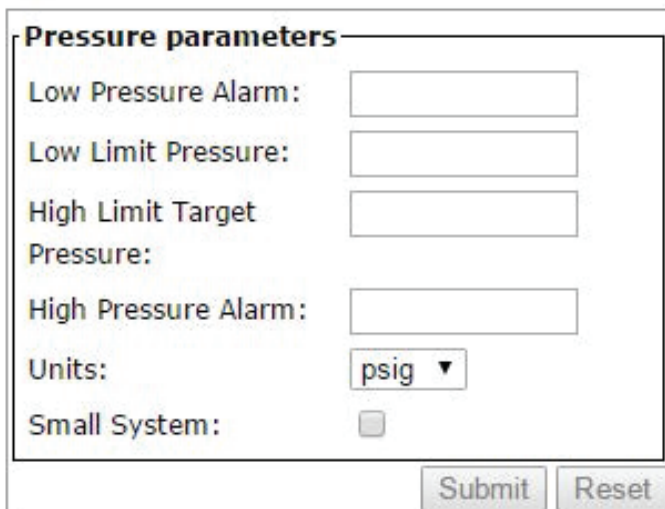

The screenshot shows a web interface titled "Pressure parameters". It contains several input fields: "Low Pressure Alarm:", "Low Limit Pressure:", "High Limit Target Pressure:", and "High Pressure Alarm:". Below these is a "Units:" dropdown menu currently set to "psig" with a downward arrow. At the bottom left is a "Small System:" checkbox, which is unchecked. At the bottom right are "Submit" and "Reset" buttons.

FIGURE 21. Pressure Parameters.

## IP CONFIGURATION

1. Go to the Configuration page.
2. If using a fixed IP address, select "Use the following IP address:" Then, set the IP address, mask, and gateway. See Figure 22.
3. If using DHCP, select "Obtain IP address automatically."
4. Click Submit. You should see a message that the dehydrator is rebooting, unless the new information is the same as the old.
5. Reconnect to the dehydrator using the new IP address. Also, change the Ethernet cable at the dehydrator to connect to the network instead of the laptop. We recommend powering down the unit while doing this.

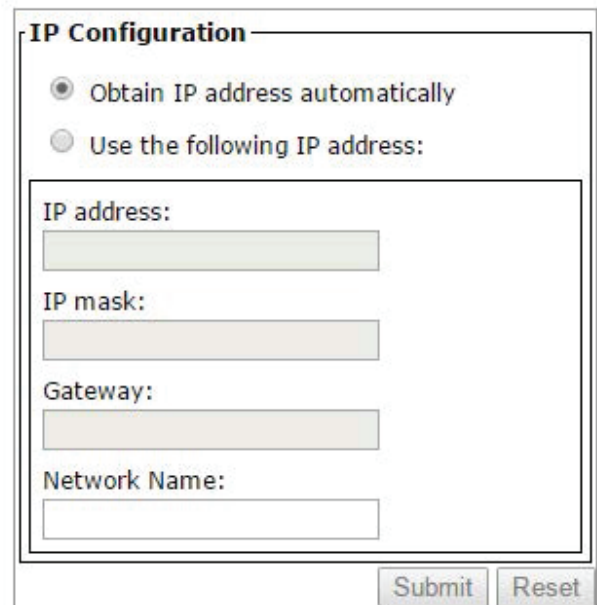

The screenshot shows a web interface titled "IP Configuration". It has two radio button options: "Obtain IP address automatically" (which is selected) and "Use the following IP address:". Below these are four input fields: "IP address:", "IP mask:", "Gateway:", and "Network Name:". At the bottom right are "Submit" and "Reset" buttons.

FIGURE 22. IP Configuration.



## SNMP PARAMETER FIELDS

1. Go to the Configuration page. Locate the SNMP Parameters fields. See Figure 22.1.
2. SNMP V2 Parameters
  - These fields are for information only
  - Though the interface implements SNMP V2 parameters the system actually uses the SNMP V1 protocol.
3. SNMP Community Parameters
  - These define who can read and write to the ADH NETCOM

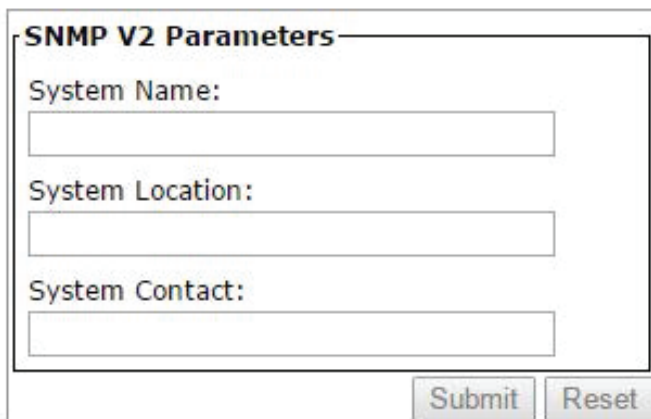

The screenshot shows a web form titled "SNMP V2 Parameters". It contains three text input fields: "System Name:", "System Location:", and "System Contact:". At the bottom right of the form are two buttons: "Submit" and "Reset".



The screenshot shows a web form titled "SNMP Community parameters". It contains three text input fields: "Read Community:", "Write Community:", and "Trap Community:". At the bottom right of the form are two buttons: "Submit" and "Reset".

FIGURE 22.1. SNMP parameter fields.

## TRAP CONFIGURATION

Traps offer the benefit that an M&C (monitor and control) system can receive automatic alerts about alarm conditions, without having to run a device check.

A trap message will be sent whenever an alarm condition appears or disappears. A trap message will also be sent on startup, or when traps are first enabled.

There are six possible trap configurations supported:

- No Traps: This is the default configuration.
- SNMP: Sends a trap message to an SNMP manager, using standard protocols. See Figure 23.
- Dual SNMP: Same as the SNMP configuration, but the trap messages are sent to two separate SNMP managers. See Figure 23.
- TCP: Trap messages are sent via TCP. See Figure 23.1.
- Simple UDP: A single trap message is sent via UDP. See Figure 23.2.
- UDP With Repeats: Trap messages are sent via UDP, and can be acknowledged by the M&C system. If it is not acknowledged, the message will be resent at regular intervals until it is acknowledged. See Figure 23.2.

In all cases, the user can configure the address to which the trap message is sent. Either the default port (which is the standard port 162 for SNMP, or 52093 for custom UDP or TCP messages), or a different port can be used. Either an IP address or network name needs to be provided for the destination of the trap messages. In the case of dual SNMP, two separate addresses need to be provided. In the case of UDP with repeats, you also specify the time between retries (in seconds).

**If you are using SNMP traps, you also need to specify a trap community. This is done in the configuration page. For SNMP, the trap message is a list of '+'s and '-'s, one for each possible alarm condition.**

**Trap Configuration**

Trap Type:

Trap Destination

Port:  Standard  Other

IP Address:

**Trap Configuration**

Trap Type:

Trap Destination

Port:  Standard  Other

IP Address:

Secondary Trap Destination

Port:  Standard  Other

IP Address:

FIGURE 23. SNMP and dual SNMP fields.

**Trap Configuration**

Trap Type:

Trap Destination

Port:  Standard  Other

IP Address:

FIGURE 23.1. TCP field.

For UDP or TCP, the message consists of the single letter T, followed by six hex digits (in upper case). These form a 24-bit binary number, where bit N is set if alarm number N is active.

**Trap Configuration**

Trap Type:

Trap Destination

Port:  Standard  Other

IP Address:

**Trap Configuration**

Trap Type:

Repeat Param (secs):

Trap Destination

Port:  Standard  Other

IP Address:

FIGURE 23.2. UDP and UDP with repeat fields.

UDP commands. A command starts with a letter V, and can be followed by a variable.

V : (no parameters) This tells the NETCOM to send a trap message. For testing to check trap messages are sending and or receiving.

V? : This returns the current alarms, as a six-digit hex number. For testing purposes.

VHH..H : this is for the purposes of acknowledging the trap (which is only useful in the case of UDP with repeats). The HH...H is a hex number, at most 24 bits, which should represent the current alarm conditions, as received in the trap message. If it matches the real alarm conditions, the trap is acknowledged. This is necessary to take care of the case where a new trap message is sent and lost at the same time the previous one is acknowledged.

For testing purpose, we have added a feature to the tools web page, which forces the sending of a trap message. This has no effect if traps are not enabled.

### TRAP ALARMS, NUMBERS, AND HEX NUMBERS

DESCRIPTION	NUMBER	HEX NUMBER
Low Pressure	1	00 00 00 01
High Pressure	2	00 00 00 02
High Duty Cycle	3	00 00 00 03
High Temperature	4	00 00 00 04
Low Temperature	5	00 00 00 05
Unused	6	00 00 00 06
Canister 1 Won't Heat	7	00 00 00 07
Canister 1 Won't Cool	8	00 00 00 08
Canister 2 Won't Heat	9	00 00 00 09
Canister 2 Won't Cool	10	00 00 00 0A
Unable To Pressurize	11	00 00 00 0B
Dew Point Alarm	12	00 00 00 0C
Compressor Won't Time-out (For Future Use)	13	00 00 00 0D
Communications Error	14	00 00 00 0E
Canister 1 Thermistor Bad	15	00 00 00 0F
Canister 2 Thermistor Bad	16	00 00 00 10
Ambient Thermistor Bad	17	00 00 00 11
Overpressure	18	00 00 00 12
Bad Calibrations In EEPROM	19	00 00 00 13
Bad Limits In EEPROM	20	00 00 00 14
Short Cycling	21	00 00 00 15
Pump Shut Down Due To Error Condition	22	00 00 00 16

## SERIAL PORT CONFIGURATION

Two dehydrators can be configured so that one controls the operation of the other. To configure one dehydrator to be master over another perform the steps below.

1. Locate the section of the set-up field called "Set as Master Dehydrator via" among the fields on the Configuration page. Refer to Figure 24.
  2. To configure the slave unit, check "None" in the "Set as Master Dehydrator via" box. Click Submit at the bottom for the settings to take effect.
  3. To configure the master unit, perform steps 3a through 3c below.
    - 3a. If using either the RS-232 or the RS-422 port, enter the S-A address of the slave unit.
    - 3b. If using a fixed IP address, click the IP address box, then enter the IP address of the slave unit on that line.
    - 3c. If using network names, click the network name box, then enter the network name of the slave unit on that line.
  4. Checking the Pullups box guarantees a defined idle state when no communication is present. At least one connected device should have pullups enabled. Pullups are always enabled in port B.
- Checking the Slow box selects operation at 1200 baud rather than the normal 9600 baud.
5. Click Submit at the bottom for the settings to take effect.
  6. Check the Parallel Master box to configure a mode where the master and the slave units operate their pumps at the same time, to achieve higher flow rates.

## RESET (THE RESET BUTTON)

A Reset button is located on the back panel. This button is used in the event it becomes necessary to reset the unit's IP address back to its original factory default IP address. The Reset button should never be used during normal operations but only by qualified personnel performing troubleshooting work on the unit. To use the Reset button to reset the unit's IP address back to the original factory default IP address, perform the following steps.

1. Turn off power to the unit. Because there is no On/Off power switch on the NEMA unit, for this procedure, leave the power cable wires attached to the power connector, loosen, but do not remove, the two captive jack screws that secure the power connector to the mating connector. Holding power connector, gently pull the assembly away from the unit and the power will shut off.
2. Press and hold the Reset button on the connection panel. While still pressing the Reset button, turn unit power back on by putting the power connector assembly back in place until unit power is restored.
3. Once the power is restored, continue to hold down the Reset button until the red Alarm LED starts to flash, then release the Reset button. The green Power LED should come on and the red Alarm LED should go off. You should hear the solenoids click into action and the compressor should pressurize the line.
4. Attach the Ethernet cable and communicate with the dehydrator using the default IP address 192.168.52.9. It might take a minute or two for the dehydrator to initialize communications, but you should be able to bring up the Status page with a web browser.

The screenshot shows a web interface titled "Serial Port Configuration". It contains several sections:

- RS422A**: A dropdown menu set to "Unused", with checkboxes for "Slow" and "Pullups".
- RS422B**: A dropdown menu set to "Unused", with a "Slow" checkbox.
- RS232**: A dropdown menu set to "Unused", with a "Slow" checkbox.
- End-of-line character:** A dropdown menu set to "CR".
- Use metric units:** An unchecked checkbox.
- Legacy pressure range:** A dropdown menu set to "Low".
- SA Address:** An empty text input field.
- Set as Master Dehydrator via:** A section with radio buttons for "None", "SA Address:", "IP Address:", and "Network Name:". Each radio button is followed by an empty text input field. There is also a checkbox for "Parallel Master".
- Buttons:** "Submit" and "Reset" buttons at the bottom right.

FIGURE 24. Serial port configuration.

## POWER CONNECTOR AND MATING CONNECTOR

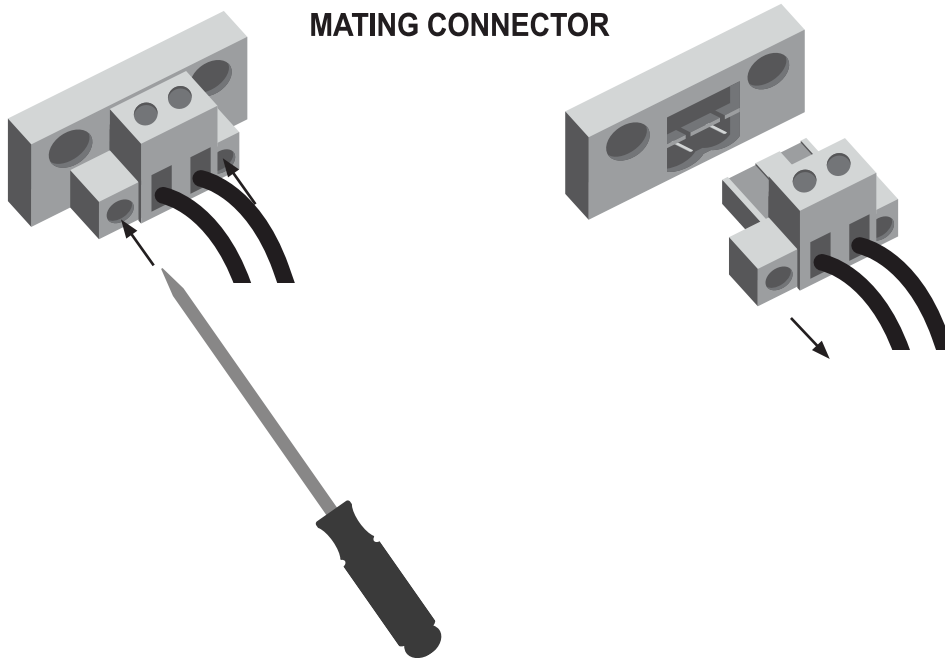

### ALARMS

The ADH NETCOM automatic air dehydrator alerts the user to a variety of alarm conditions. These conditions are described below. Most alarm condition parameters are configurable by the user. It is useful to explain the user-configurable alarm conditions that can affect or impact dehydrator performance most often. You can also refer to the Glossary at the front of this Manual for additional information.

#### USER-DEFINED ALARM VARIABLES

**High Pressure Alarm Level** - The user-configurable high pressure limit at which an alarm condition will be indicated. Note that the High Pressure Alarm Level must be set higher than the High Limit Target Pressure setting, and that the factory default setting is 1.5 psig, or 103.5 mbar. A High Pressure Alarm occurs if the pressure exceeds the configured High Pressure Alarm Level for more than 30 seconds.

**Low Pressure Alarm Level** - The user-configurable low pressure limit at which an alarm condition will be indicated. Note that the Low Pressure Alarm Level setting must be set lower than the Low Limit Target Pressure setting, and that the factory default setting is 0.15 psig or 10 mbar.

A Low Pressure Alarm occurs if the pressure stays below the configured Low Pressure Alarm Level for more than 30 seconds.

**High Duty Cycle Alarm Level** - The configurable set point at which the unit will indicate a high duty cycle. The factory default setting is 50%. The system duty cycle and the discharge pressure are available for display. Typically, the system should be "tight" enough to limit the duty cycle to less than 20%. System component life decreases as duty cycle increases. A Duty Cycle Alarm occurs if the duty cycle exceeds the configured Duty Cycle Alarm level.

**ADH NETCOM alarm and warning conditions are presented in the table on the next page.** The numbers associated with each specific condition are used again in the Troubleshooting section of this manual to help connect the indicated condition with an appropriate solution. In the table on the next page, an "A" designates an Alarm condition, while "W" designates a Warning condition. These designations are for "backward" software compatibility with earlier dehydrator models and the indication of any condition, whether an alarm or a warning, needs to be addressed and corrected as soon as possible.

## ADH NETCOM ALARMS (A) AND WARNINGS (W) AND THEIR DEFINITIONS

FLOW CHART SLIDE	ALARM / WARNING NUMBER	DESCRIPTION
3	A1	Low Pressure
4	A2	High Pressure
3	W3	High Duty Cycle
5	W4	High Temperature
5	W5	Low Temperature
-	W6	Unused
6	A7	Canister 1 Won't Heat
7	A8	Canister 1 Won't Cool
6	A9	Canister 2 Won't Heat
7	A10	Canister 2 Won't Cool
3	A11	Unable To Pressurize
8	A12	Dew Point Alarm
-	W13	Unused
9	W14	Communications Error (Master Units Only)
6	A15	Canister 1 Thermistor Bad
6	A16	Canister 2 Thermistor Bad
5	A17	Ambient Thermistor Bad
4	A18	Overpressure
11	A19	Bad Calibrations In EEPROM
11	A20	Bad Limits In EEPROM
12	A21	Short Cycling
13	A22	Pump Shut Down Due To Error Condition

### CONFIGURING THE ALARM RELAYS

The Alarm Relay Configuration Screen presented in Figure 25 is used to configure the three alarm relays as desired.

Figure 25. Alarm relays configuration.

**Alarm Relays**

This dehydrator has three relays for annunciating alarm conditions. Select the alarms below that you wish to associate with each alarm relay.

	1	2	3
1: Low Pressure	<input type="checkbox"/>	<input type="checkbox"/>	<input type="checkbox"/>
2: High Pressure	<input type="checkbox"/>	<input type="checkbox"/>	<input type="checkbox"/>
3: Leaky (high duty cycle)	<input type="checkbox"/>	<input type="checkbox"/>	<input type="checkbox"/>
4: Too Hot	<input type="checkbox"/>	<input type="checkbox"/>	<input type="checkbox"/>
5: Too Cold	<input type="checkbox"/>	<input type="checkbox"/>	<input type="checkbox"/>
6: Not used	<input type="checkbox"/>	<input type="checkbox"/>	<input type="checkbox"/>
7: Canister 1 Won't Heat	<input type="checkbox"/>	<input type="checkbox"/>	<input type="checkbox"/>
8: Canister 1 Won't Cool	<input type="checkbox"/>	<input type="checkbox"/>	<input type="checkbox"/>
9: Canister 2 Won't Heat	<input type="checkbox"/>	<input type="checkbox"/>	<input type="checkbox"/>
10: Canister 2 Won't Cool	<input type="checkbox"/>	<input type="checkbox"/>	<input type="checkbox"/>
11: Very Leaky (Shut Down)	<input type="checkbox"/>	<input type="checkbox"/>	<input type="checkbox"/>
12: Dew Point Alarm	<input type="checkbox"/>	<input type="checkbox"/>	<input type="checkbox"/>
13: Not used	<input type="checkbox"/>	<input type="checkbox"/>	<input type="checkbox"/>
14: Communications Error	<input type="checkbox"/>	<input type="checkbox"/>	<input type="checkbox"/>
15: Canister 1 Thermistor Bad	<input type="checkbox"/>	<input type="checkbox"/>	<input type="checkbox"/>
16: Canister 2 Thermistor Bad	<input type="checkbox"/>	<input type="checkbox"/>	<input type="checkbox"/>
17: Ambient Thermistor Bad	<input type="checkbox"/>	<input type="checkbox"/>	<input type="checkbox"/>
18: Overpressure	<input type="checkbox"/>	<input type="checkbox"/>	<input type="checkbox"/>
19: Calibration Corrupted	<input type="checkbox"/>	<input type="checkbox"/>	<input type="checkbox"/>
20: Pressure Limits Corrupted	<input type="checkbox"/>	<input type="checkbox"/>	<input type="checkbox"/>
21: Short Duty Cycle	<input type="checkbox"/>	<input type="checkbox"/>	<input type="checkbox"/>
22: Abandoned Pumping	<input type="checkbox"/>	<input type="checkbox"/>	<input type="checkbox"/>

## STATUS SCREEN

This can be used to monitor the operation of the ADH NETCOM.

## NORMAL OPERATION

During normal operation the ADH NETCOM automatic air dehydrator begins functioning automatically when power is applied. No operator intervention is required after initial installation and system configuration have been completed.

During normal operation, the Status Screen is the screen the operator will see and use most often. Refer to Figure 1 on the following page for a complete description of the information presented on the Status Screen.

## INDICATORS

The ADH NETCOM has two LED indicators, located on its front panel. The Power indicator lights whenever power is applied to the unit. The Alarm indicator functions as a

summary alarm and lights to indicate the presence of any of several alarm or warning conditions. When an Alarm condition is indicated there, the specific alarm condition can be found by connecting to the system using the Ethernet connection and viewing the Status information. The alarm condition will be displayed there.

## STATUS INFORMATION

To obtain operational status information for the ADH NETCOM, use either the simple web interface or query the dehydrator via SNMP. Optionally, the dehydrator may be queried using the Scientific-Atlanta protocol via one of the serial ports on the back of the units or by using UDP. Refer to Appendix C.

## PLACING A DEHYDRATOR IN STANDBY

The ADH NETCOM can be switched between online or standby mode either through the web interface, by issuing an SNMP command, or by issuing a standby command using the Scientific-Atlanta Protocol.

## SETTINGS PAGE ELEMENTS

FUNCTION	DESCRIPTION
Standby	Places the dehydrator offline
Online	Returns the dehydrator to online or active status
Machine Identification	Shows hardware, firmware, software, and IP identity
Status Button	From any screen click to display the Main or Status Screen
Configuration Button	From any screen click to view, set, or change parameters
Tools Control Button	From any screen click to enter Tools page
NetworkETI Button	From any screen click to go to ETI web site
Alarm Window	Displays any current alarm conditions
Refresh Indicator	A configurable indicator of how often the screen updates
Pressure	Current system pressure based on currently active canister
Duty Cycle	A percentage expression of "Pumping" information
Pumping	A ratio showing actual Pumping time relative to operating time
Temperature	Ambient temperature inside box but outside of canisters
Compressor Hours	Cumulative hours since dehydrator first pumped
Control	Indicates unit command source: Slave, Master, or Master Offline
Status	Indicates current state: Normal, Standby, Leaky, or Remote
Canister One / Canister Two	Each line displays Control State: Ready, Full, Init., or Dead; and Usage State: Idle, In Use, or Regenerating

## TOOLS SCREEN

Click the Tools tab to access the Tools Screen. The Tools Screen allows you to change Alarm Control, Force Canister Regeneration, Reboot the Dehydrator, or Send a Trap Message, See Figure 26.

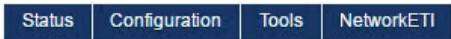

### Available Tools

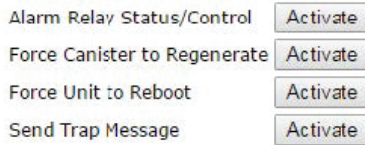

The **Alarm Relay Status/Control** button allows the user to manually initiate an alarm.

### ADH NETCOM Alarm Status and Control Section:

Current mode: Automatic  
Time until reversion to auto: -- seconds

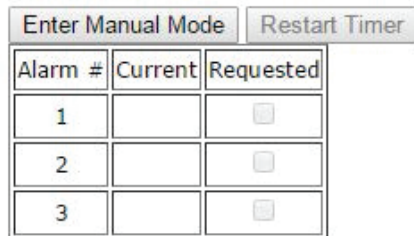

The **Force Canister to Regenerate** button allows the user to regenerate one or both canisters (canisters will regenerate one at a time).

### ADH NETCOM: Forcing Canisters into Regeneration



The **Force Unit to Reboot** button allows the user to reboot the ADH NETCOM unit from a remote location.



The **Send Trap Message** button allows the user to initiate a Trap alarm message.



Figure 26. Tools screen functions.

## MAINTENANCE

### PREVENTIVE MAINTENANCE

The ADH NETCOM automatic air dehydrator requires no preventive maintenance. All components are designed for a minimal operational life of 15 years at duty cycles up to 20%. Higher duty cycles may reduce component life.

### CORRECTIVE MAINTENANCE

Verifying the performance of the ADH NETCOM requires special equipment, fixtures, and expertise. Please consult with Environmental Technology Customer Service before attempting to service or repair an ADH NETCOM unit.

### WARNING

Servicing should be performed by qualified personnel. ADH NETCOM dehydrators contain lethal voltages. Assume that all circuits are live. Attached ADH NETCOM automatic air dehydrators may produce as much as 24 psig (1,655mbar) under worst-case failure. Vent the system to the atmosphere before servicing pneumatic components.

All fittings and hardware are in standard American dimensions, or inches. Use a solution of mild liquid dish detergent and water to locate air leaks. By convention, Drying Canister 1 is the drying canister on the left when viewed from the front of the unit.

### CAUTION

Do not apply power to the unit unless all internal connections have been made. Failure to do this may result in component damage. It is best to return the entire unit to Environmental Technology for evaluation and repair, but we realize that is not always possible. If you can determine the problem and its resolution, replacement components can be obtained from Environmental Technology.



## TROUBLESHOOTING

Presented in Table 8 below is a guide for use in Troubleshooting, showing the specific alarm or warning condition with the applicable Troubleshooting Flowchart in this section. Also refer to Figure 27.

ALARM / WARNING NUMBER	ALARM DEFINITION	FLOWCHART SLIDE
A1	Low Pressure	3
A2	High Pressure	4
W3	High Duty Cycle	3
W4	High Temperature	5
W5	Low Temperature	5
W6	Unused	-
A7	Canister 1 Won't Heat	6
A8	Canister 1 Won't Cool	7
A9	Canister 2 Won't Heat	6
A10	Canister 2 Won't Cool	7
A11	Unable to Pressurize	3
A12	Dew Point Alarm	8
W13	Unused	-
W14	Communications Error (Master units only)	9
A15	Canister 1 Thermistor Bad	6
A16	Canister 2 Thermistor Bad	6
A17	Ambient Thermistor Bad	5
A18	Overpressure	4
A19	Bad Calibrations in EEPROM	11
A20	Bad Limits in EEPROM	11
A21	Short Cycling	12
A22	Pump Shutdown Due To Error Condition	13

TABLE 8. Troubleshooting flowchart guide.

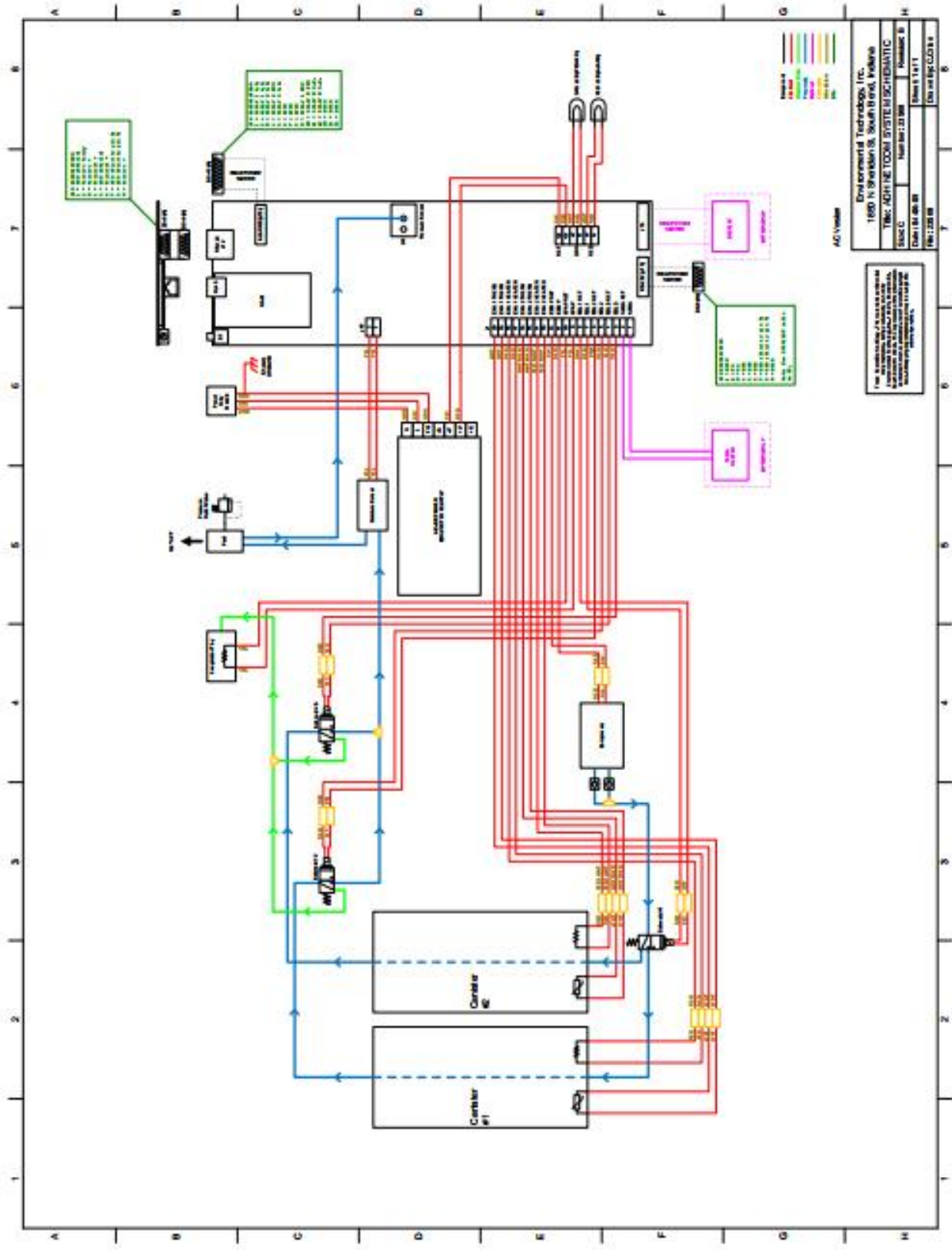
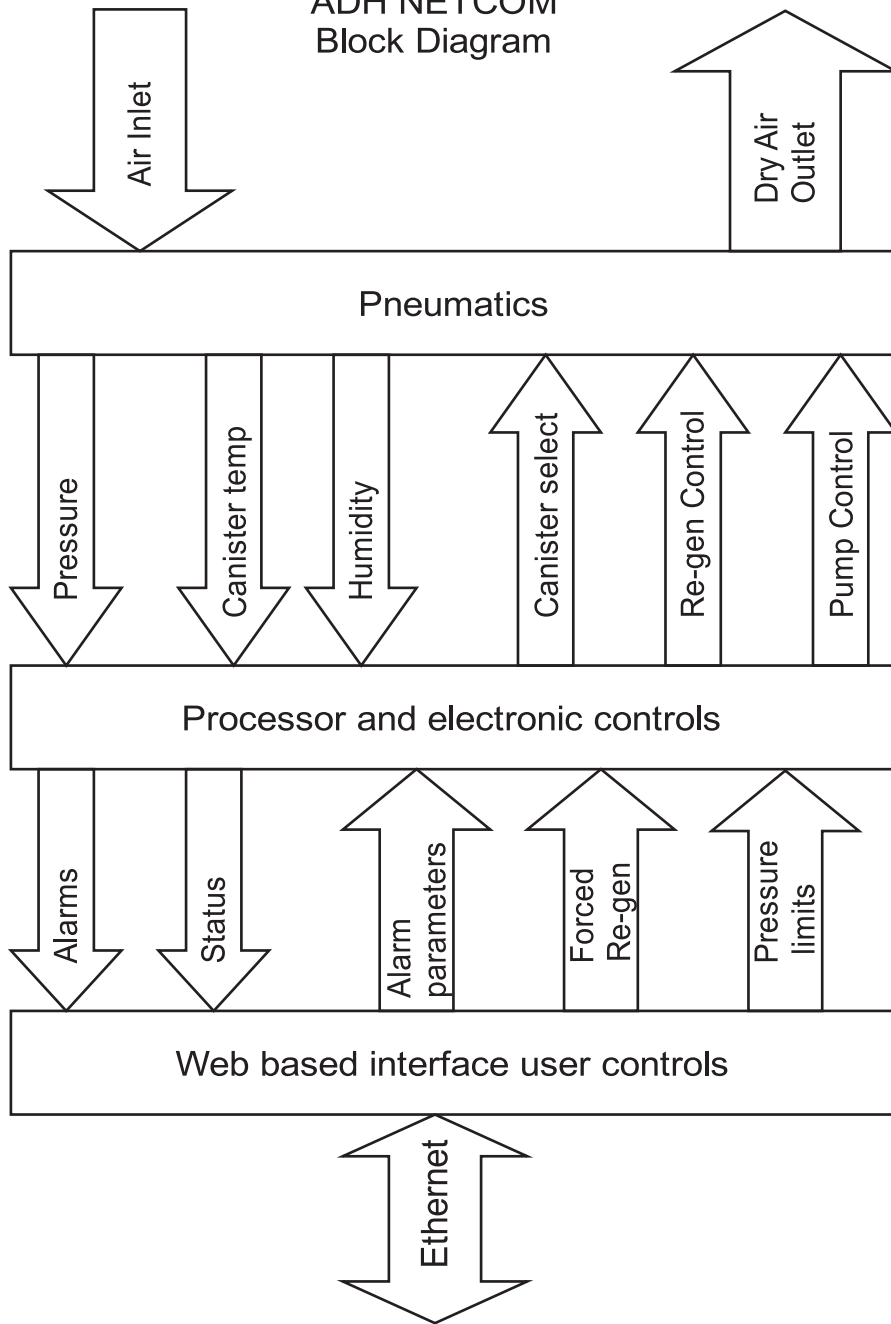

FIGURE 27. ADH NETCOM System Schematic Diagram.  
 System Schematic Also Available Online - [Download System Schematic Diagram PDF](#)

# ADH NETCOM Block Diagram

1



**ADH NETCOM TROUBLESHOOTING FLOWCHART 1.**

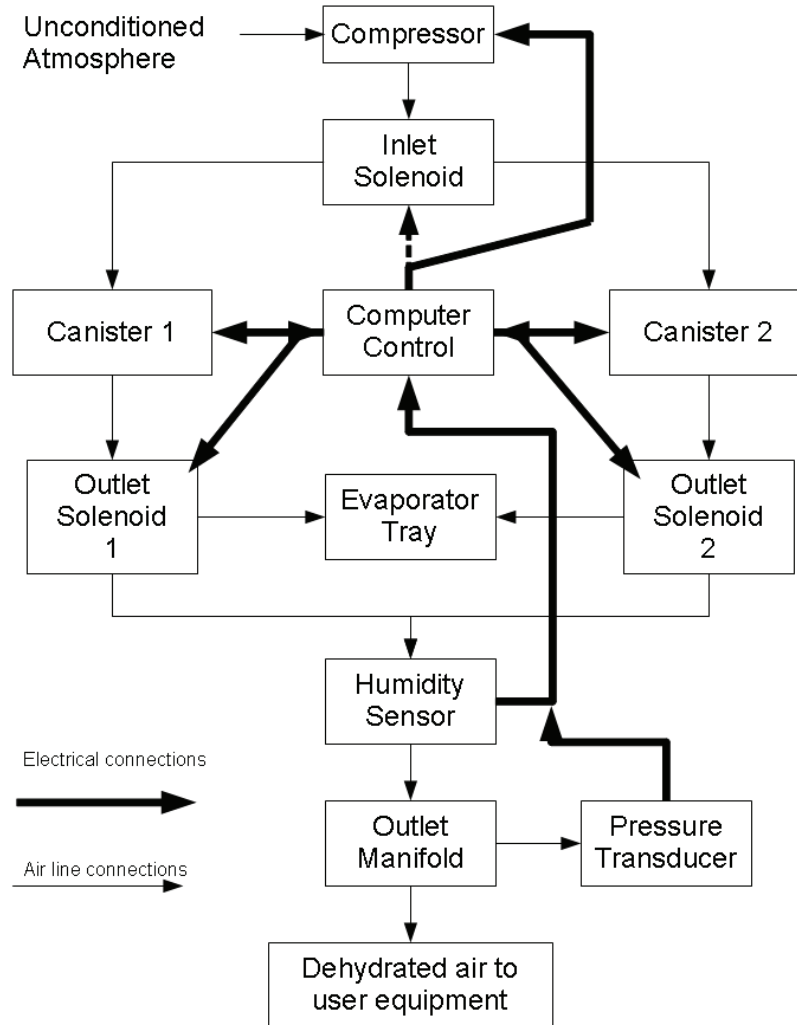

**ADH NETCOM TROUBLESHOOTING FLOWCHART 2.**

Alarms:  
 A1 Low pressure  
 W3 Leaky system  
 A11 Excessive run time

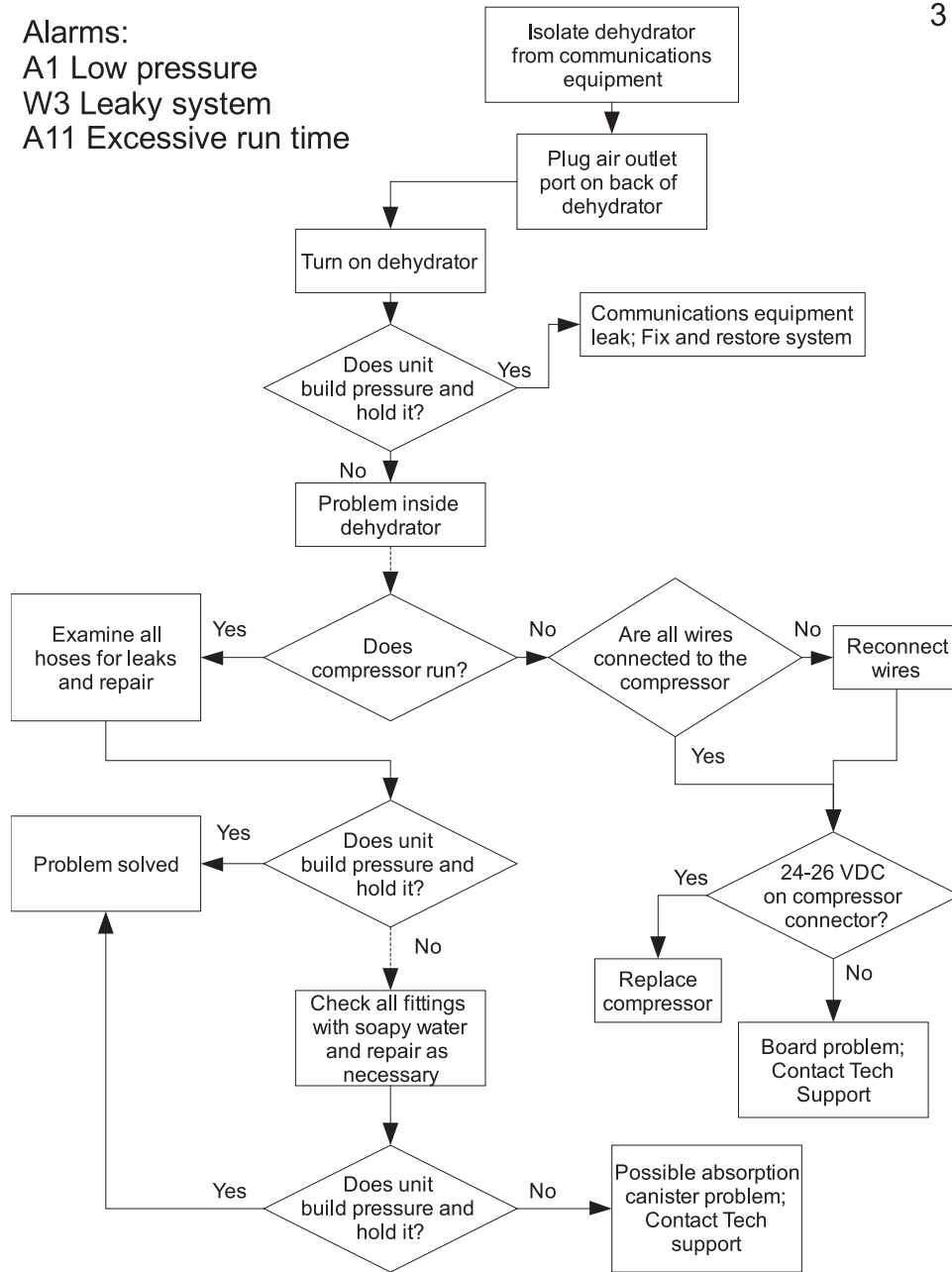

**ADH NETCOM TROUBLESHOOTING FLOWCHART 3.**

Alarms:  
A2 High pressure  
A18 Overpressure

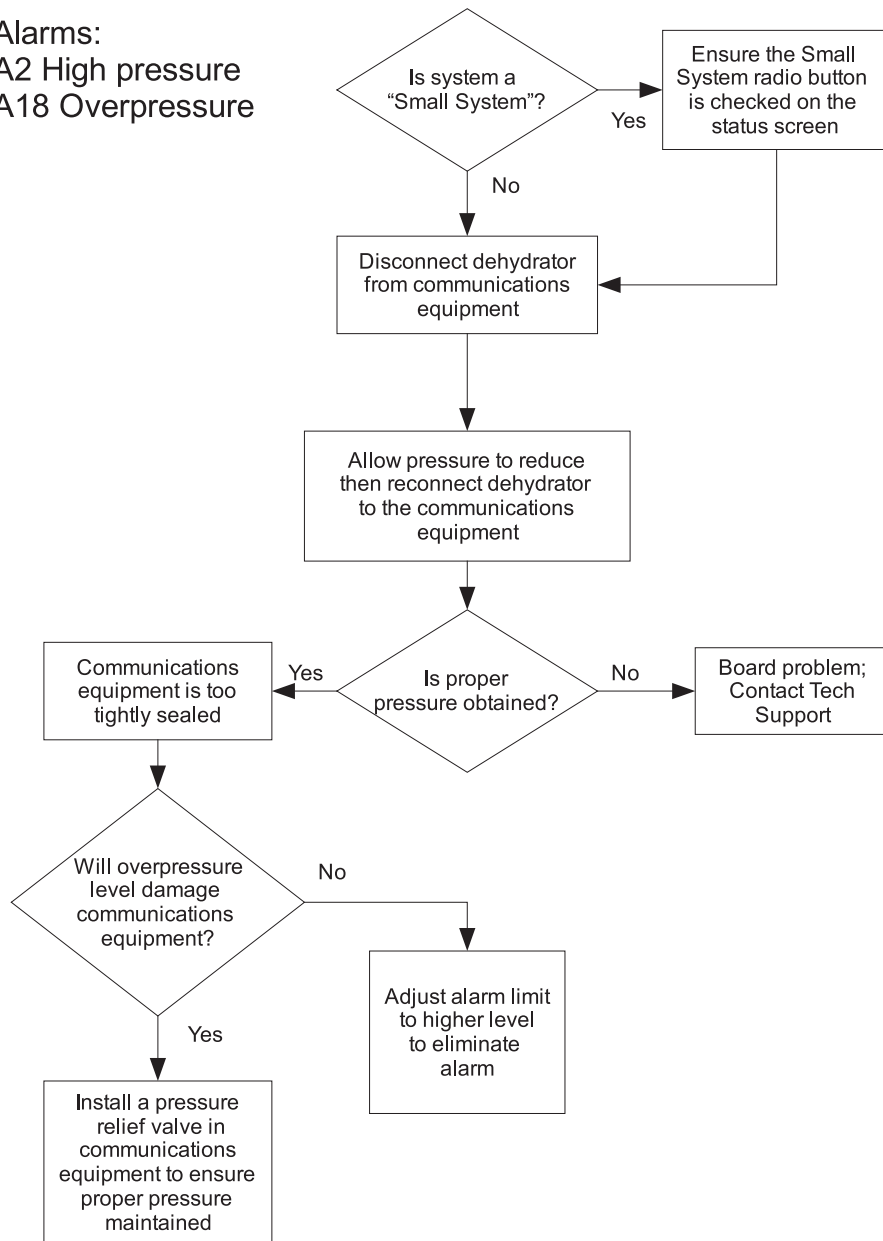

**ADH NETCOM TROUBLESHOOTING FLOWCHART 4.**

Alarms:  
 W4 High temperature  
 W5 Low temperature  
 A17 Ambient thermistor

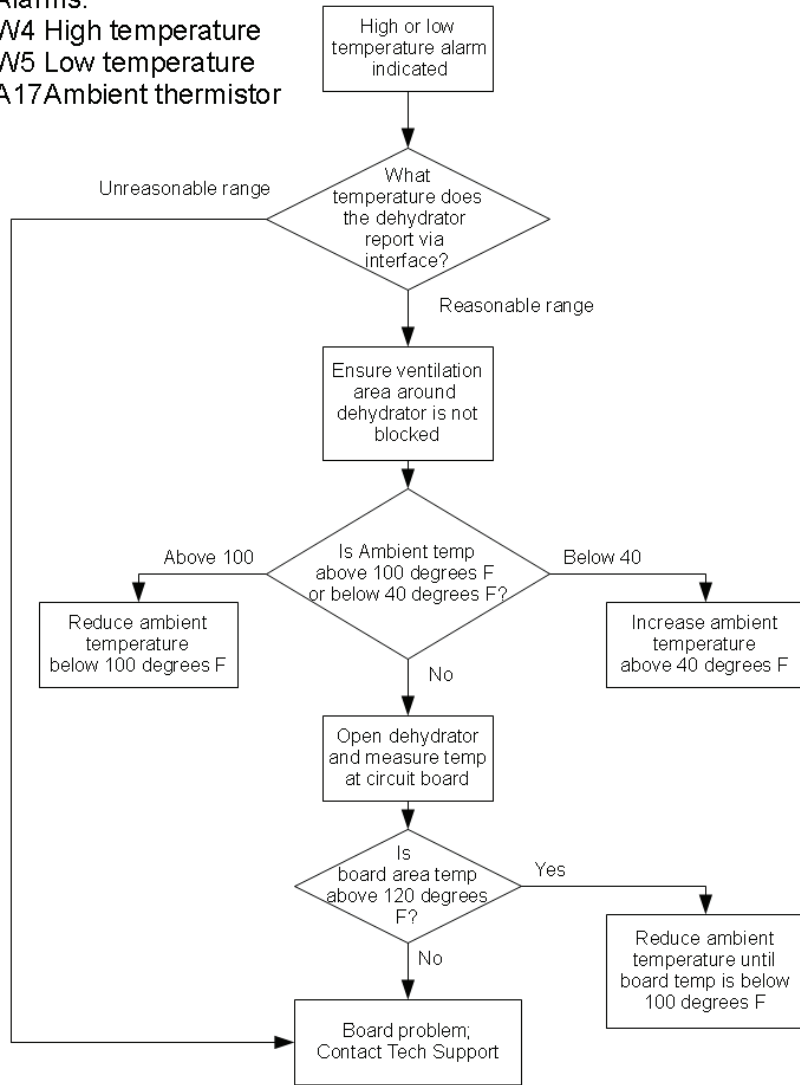

**ADH NETCOM TROUBLESHOOTING FLOWCHART 5.**

## Alarms:

A7 Absorption unit 1 won't heat

A9 Absorption unit 2 won't heat

A15 Thermistor 1 bad

A16 Thermistor 2 bad

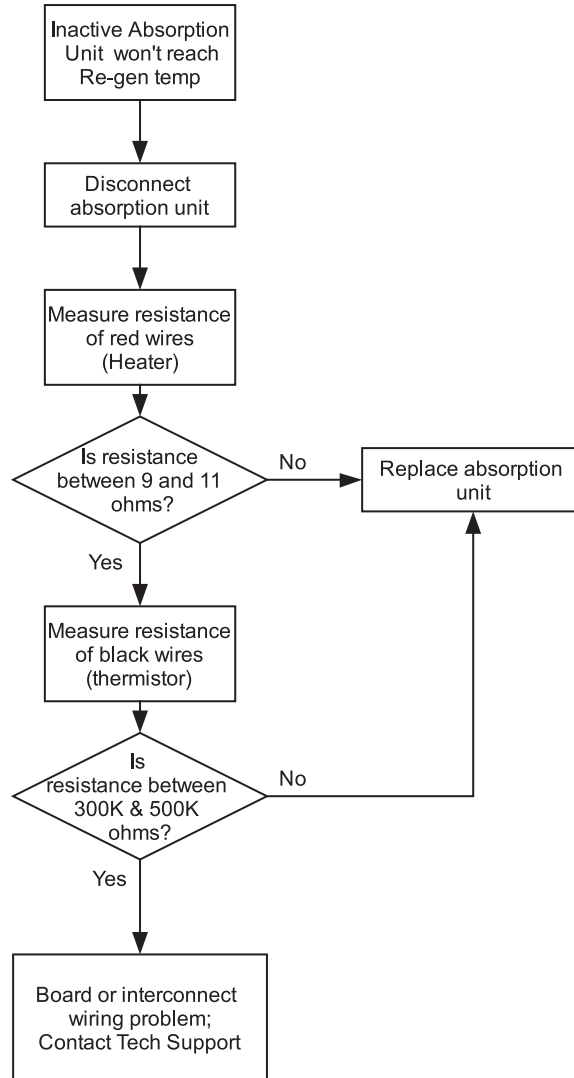

## ADH NETCOM TROUBLESHOOTING FLOWCHART 6.



Alarms:

- A8 Absorption unit 1 won't cool
- A10 Absorption unit 2 won't cool

7

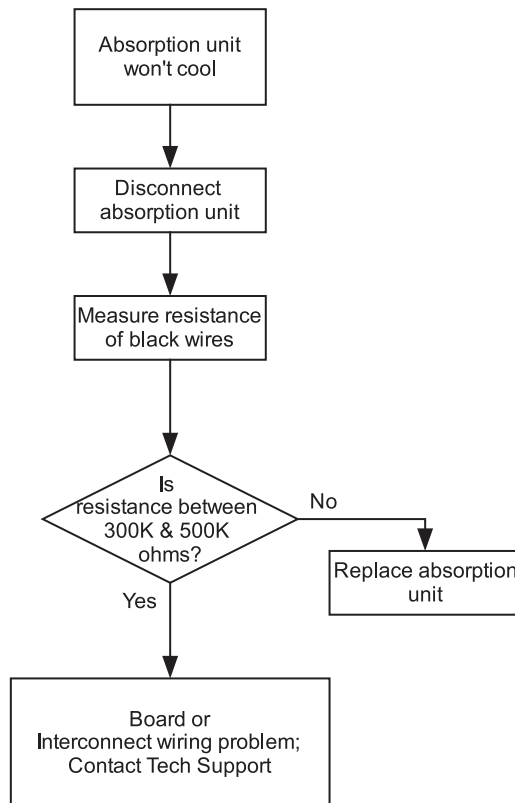

**ADH NETCOM TROUBLESHOOTING FLOWCHART 7.**

Alarm:  
A12 Dew point alarm

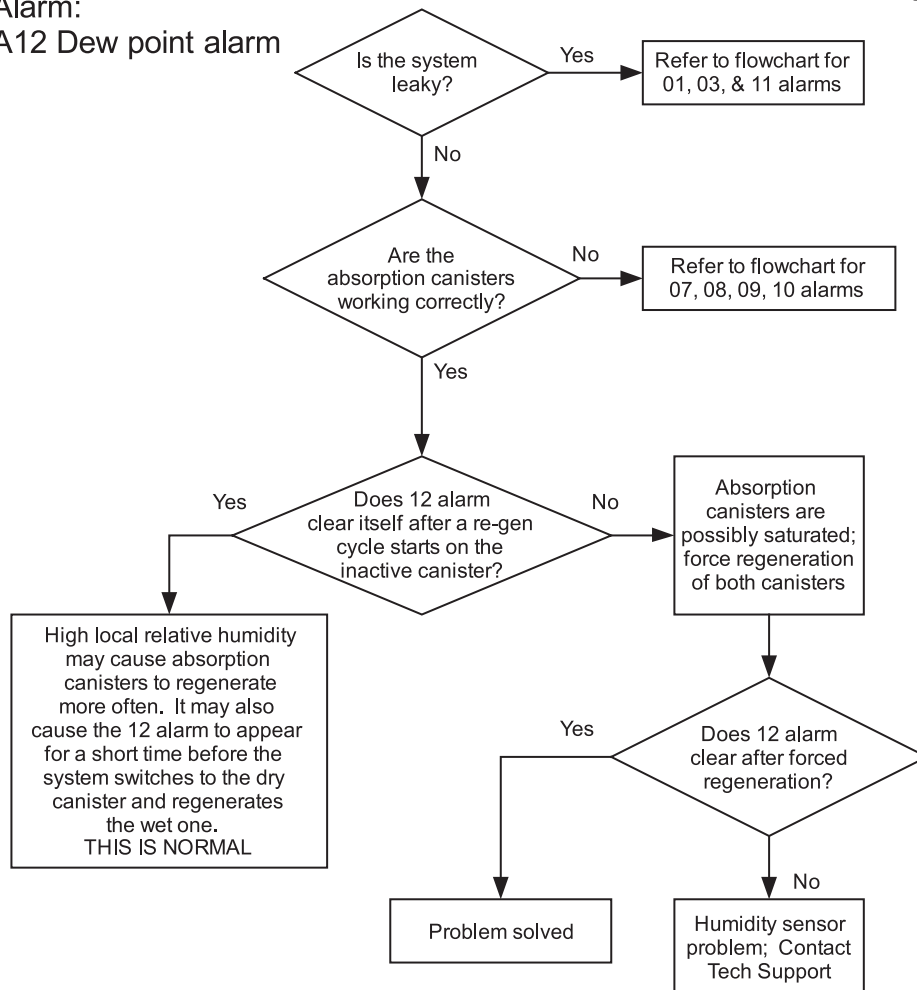

**ADH NETCOM TROUBLESHOOTING FLOWCHART 8.**

Alarm:  
W14 No Communications  
(Master / slave  
configuration only)

9

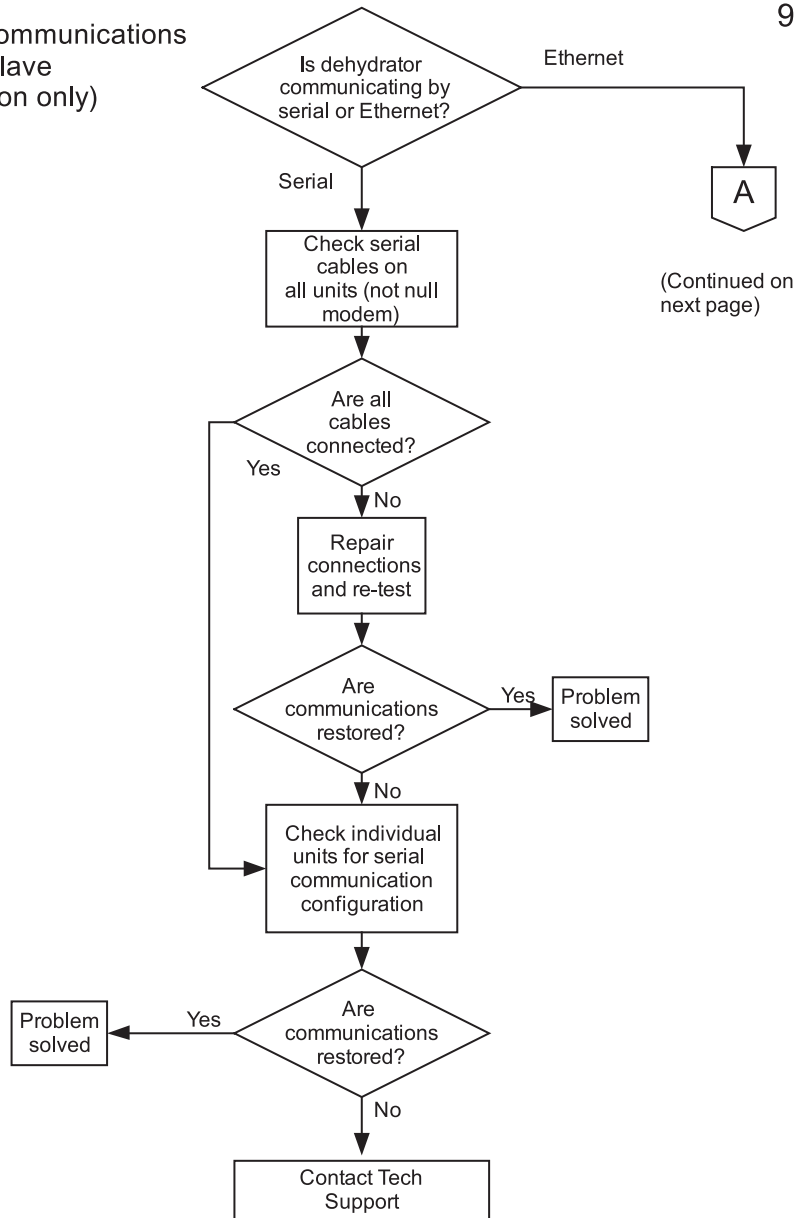

**ADH NETCOM TROUBLESHOOTING FLOWCHART 9.**

Alarm:  
(W14  
continued from  
previous page)

10

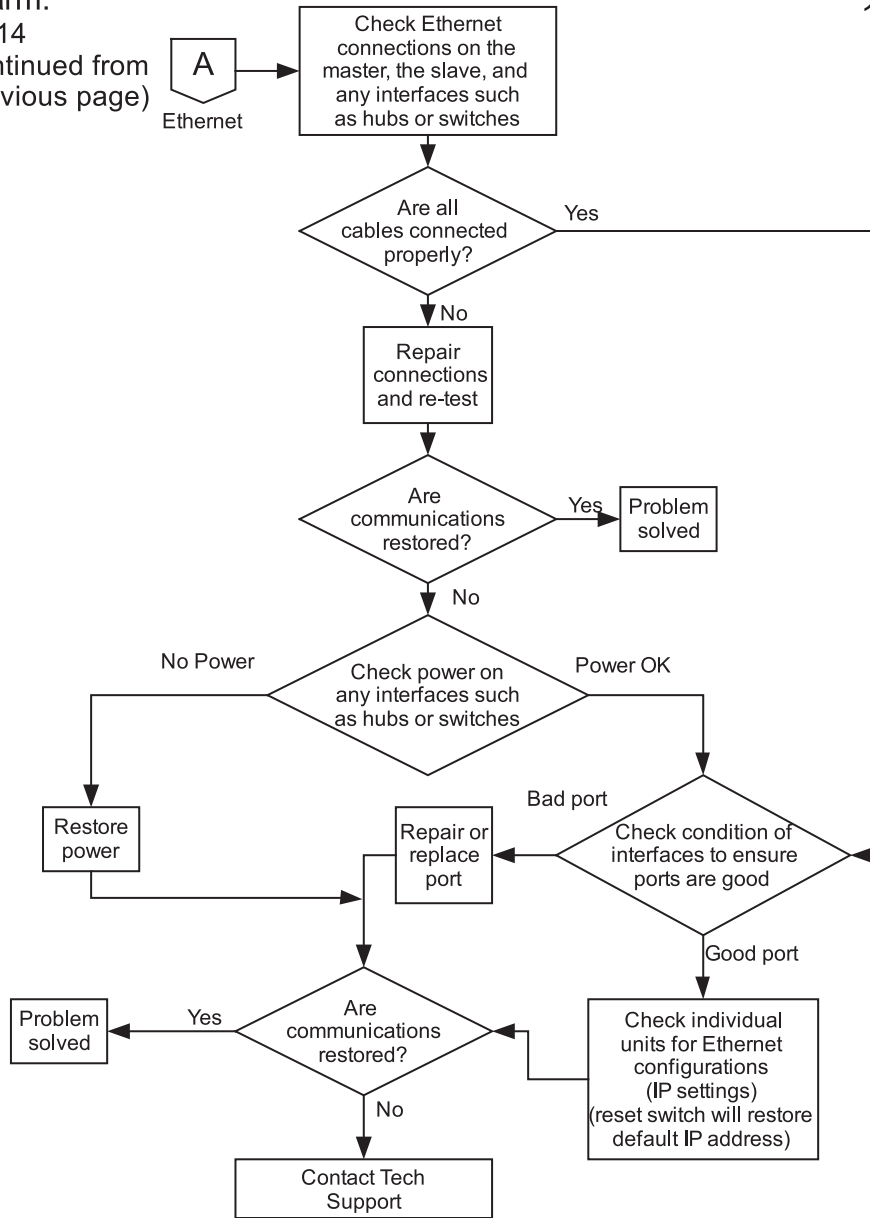

**ADH NETCOM TROUBLESHOOTING FLOWCHART 10.**

Alarm:  
A19 Bad Calibrations in EEPROM  
A20 Bad limits in EEPROM

11

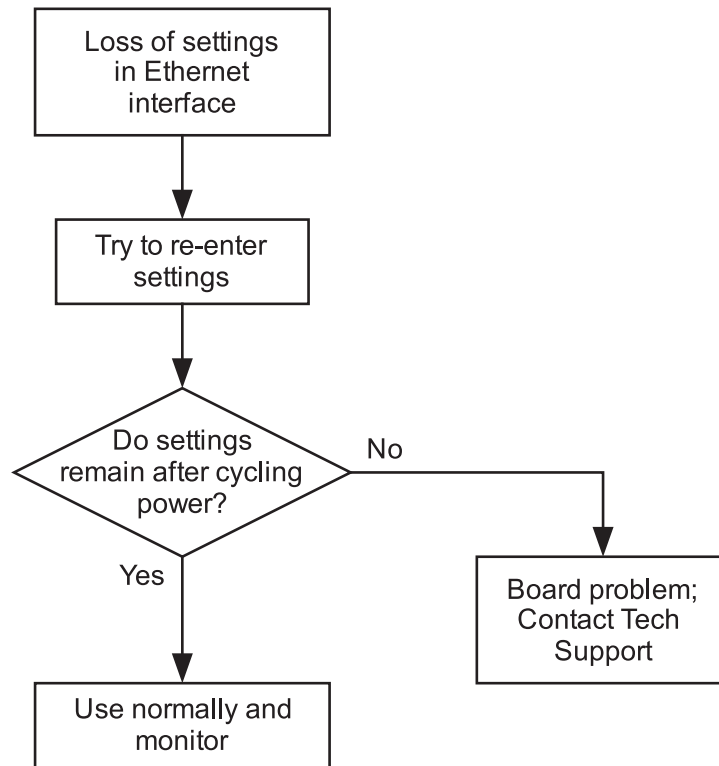

**ADH NETCOM TROUBLESHOOTING FLOWCHART 11.**

Alarm:  
A21 Short cycling

12

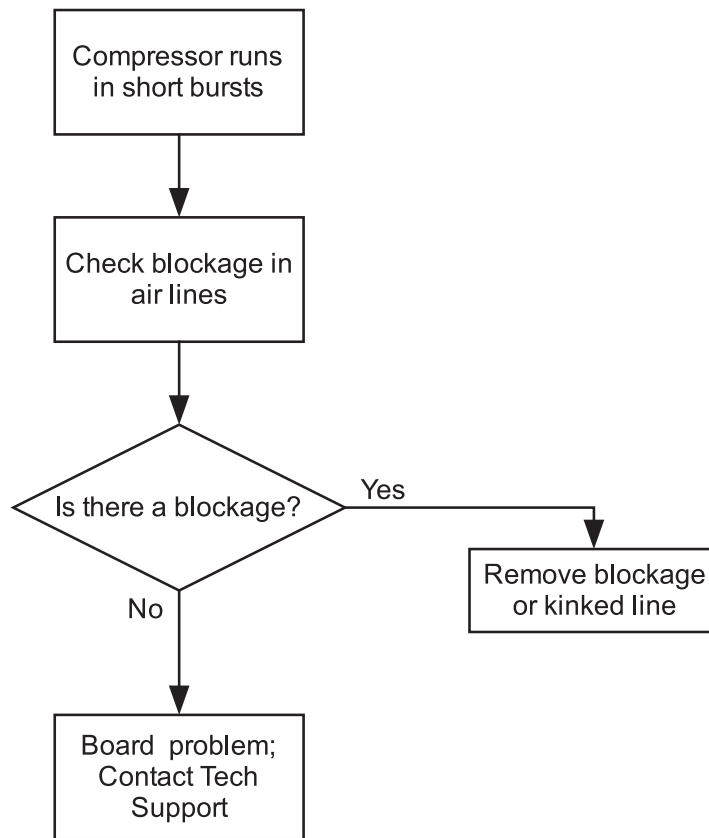

**ADH NETCOM TROUBLESHOOTING FLOWCHART 12.**

Alarm:  
A22 Pump shutdown due  
to error condition

13

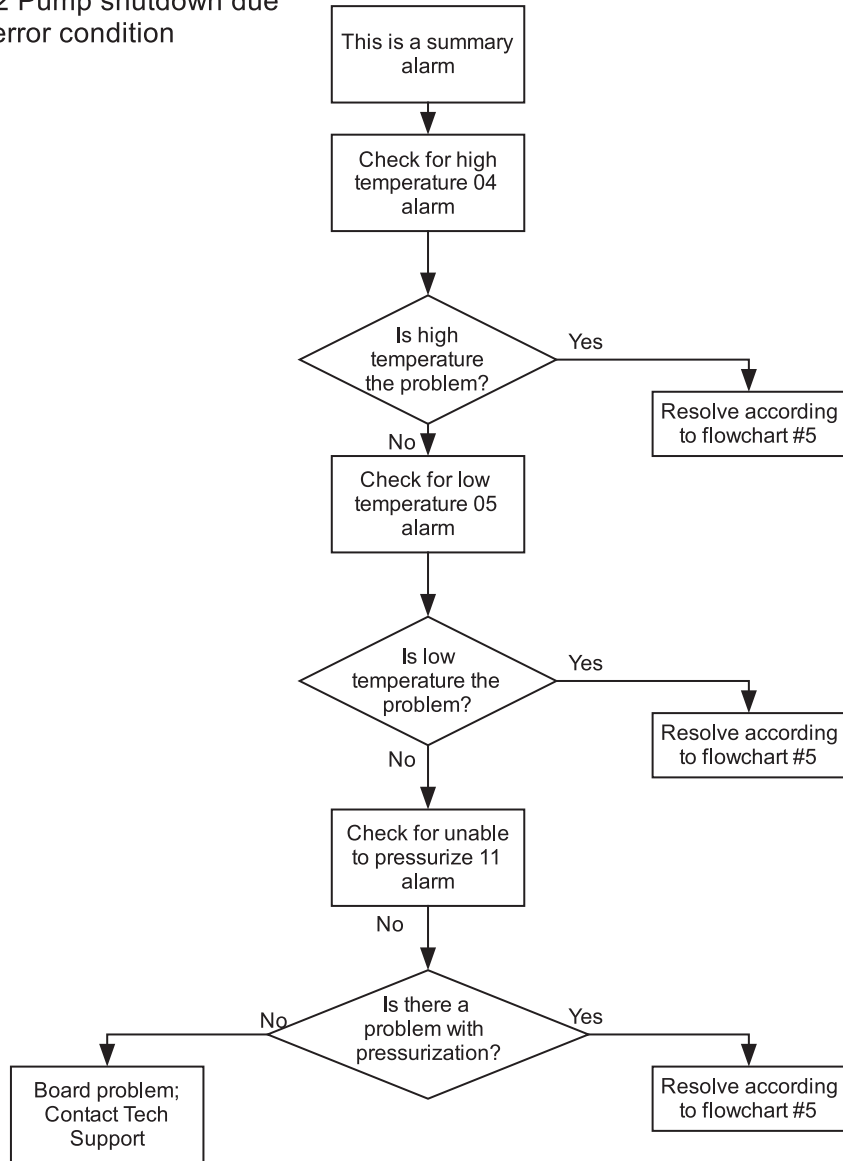

### ADH NETCOM TROUBLESHOOTING FLOWCHART 13

## REPLACEMENT PARTS

Listed below are the part names and numbers which may be used to order replacement parts for the ADH NETCOM automatic air dehydrator . To order parts for the ADH NETCOM or any ETI product, contact ETI Customer Service between the hours of 8:00 a.m. and 5:00 p.m., Eastern Time.

PART NO.	REPLACEMENT PART NO.	ITEM DESCRIPTION
23247	24486	Front Panel Assembly
23253	24084	Main Circuit Board
23216	24085	Compressor Assembly
23218	25551	Absorption Unit
23446	24086	Power Module, AC Switched (for 25526*)
23563	24087	Power Filter, RFI (for 25523*)
23173	24088	Discharge Manifold with Safety Relief Valve (for 25526*)
23549	24751	Discharge Manifold with Safety Relief Valve (for 25523*)
23269	24090	Solenoid Outlet
23270	24096	Solenoid, Inlet
23368	24091	Humidity Sensor Assembly (for 25526* and 25527*)
23707	24092	Humidity Sensor Assembly (for 25523*)
23219	24752	Evaporator Module
23445	24094	AC Power Supply
23224	24095	DC Power Supply
23526		ADH NETCOM Installation & Operation Manual (this document)
23257		Accessory Kit, ADH NETCOM, AC
23233		Accessory Kit, ADH NETCOM, DC
23572		Accessory Kit, ADH NETCOM, AC NEMA
17618		Power Cord
23245		Mounting Bracket

The Item Descriptions above that refer to numbered units are as follows:

- 25526 - ADH NETCOM, AC Unit
- 25527 - ADH NETCOM, DC Unit
- 25523 - ADH NETCOM, NEMA Unit



## SPECIFICATIONS

Specifications for the ADH NETCOM automatic air dehydrator are listed below. Refer also to the Product Label on the unit itself.

### GENERAL

Approvals	Type 1950, Information Technology Equipment Also evaluated by Underwriters Laboratories Inc® in accordance with IEC Publication 60950
-----------	--

### ENCLOSURE

Dimensions	17" × 12" × 5-1/4" (432mm × 305mm × 133mm)
Weight	16 lbs (7.26 kg)
Mounting	Dual-post rack, flush mounted Single-post rack, center mounted Wall mounted

### POWER

	AC MODEL	DC MODEL
Supply	100-240 VAC, 50/60 Hz	±20-75 VDC
Maximum Current	1.0 Amps at 100 V	5 Amps at 20 VDC
Power Usage	40 W typical; 150 W max.	40 W typical; 150 W max.
Heat Dissipation	136 BTU/hr @ 40 W; 512 BTU/hr @ 150 W	136 BTU/hr @ 40 W; 512 BTU/hr @ 150 W

### OUTPUT

Maximum Pressure	7.5 psig (517mbar)
Operating Units	SI (millibars); English (psig), default

## CONTROL

Protocols	HTTP (Web Interface), SNMP, UDP, TFTP
Maximum Pressure	Configurable Range: 0.20 psig to 7.5 psig (14mbar to 517mbar), Default: 0.50 psig (34.5mbar)
Minimum Pressure	Configurable Range: 0.10 psig to 7.4 psig (7mbar - 510mbar), Default: 0.30 psig (21mbar)
Low Pressure Alarm Level	User-Configurable, Default: 0.15 psig (10mbar)
High Pressure Alarm Level	User-Configurable, Default 1.5 psig (103.5mbar)
Alarm Relays	Contact Type - Form C, SPDT, reverse acting Ratings - 0.25 Amps @ 60 V User-Configurable, Defaults: Alarm Relay 1: Summary Alarm Alarm Relay 2: Low Pressure Alarm Alarm Relay 3: Dew Point Alarm

## ENVIRONMENTAL

Operating Temperature	32°F to 130°F +/-2°F (0°C to 55°C +/-1°C)
Storage Temperature	-40°F to 150°F (-40°C to 60°C)

## APPENDIX A – ADH NETCOM AC NEMA CONFIGURATION

### DESCRIPTION

The ADH NETCOM AC NEMA automatic air dehydrator provides the same functionality as the standard ADH NETCOM automatic air dehydrator, housed in an environmentally sheltered polypropylene, IP66, NEMA 4X enclosure. Because of the NEMA enclosure, the unit can be mounted outside which not only saves interior shelf space but also protects the unit from harmful environmental factors. While the NEMA enclosure keeps out moisture, the temperature control system allows operation down to -40°F (-40°C). Refer to Figures 1 and 2 below for views of internal components and dimensions.

Power requirements for the standard and NEMA units are the same: 100 to 240 VAC or +/-20 to 75 VDC, 50 / 60 Hz, and 1.5 Amps at 100V. Each voltage range is auto-sensing and requires no special configuration. The temperature control system in the NEMA unit allows reliable operation from -40oF (-40oC) to 130oF (55oC), with a storage temperature range from -40oF (-40oC) to 150oF (60oC).

Communications features are the same for the standard ADH NETCOM as for the NEMA configuration. Specifically, the following computer communications protocols can be used:

- Hypertext Transfer Protocol (HTTP);
- Simple Network Management Protocol (SNMP);
- User Datagram Protocol (UDP); and
- Trivial File Transfer Protocol (TFTP).

The NEMA enclosure has a dedicated temperature control system to enable outdoor operation. To save energy, small heaters are mounted near the pump to allow normal operation at temperatures below 40°F, while excess heat from those heaters is utilized within the enclosure to heat other, less temperature sensitive components. To keep moisture from collecting internally, pressurized water vapor is discharged from the dehydrator through a discharge port and diffuser during regeneration. The ADH NETCOM AC NEMA automatic air dehydrator is also available with optional Type 1 and Type 2 MIL-SPEC connectors, making field replacement quick with minimal downtime.

The ADH NETCOM automatic air dehydrator is available in various configurations and installation is not the same for all of them. Although this Appendix describes installation, the Installation Sheet that came with your unit is the best source for installation information for your specific configuration.

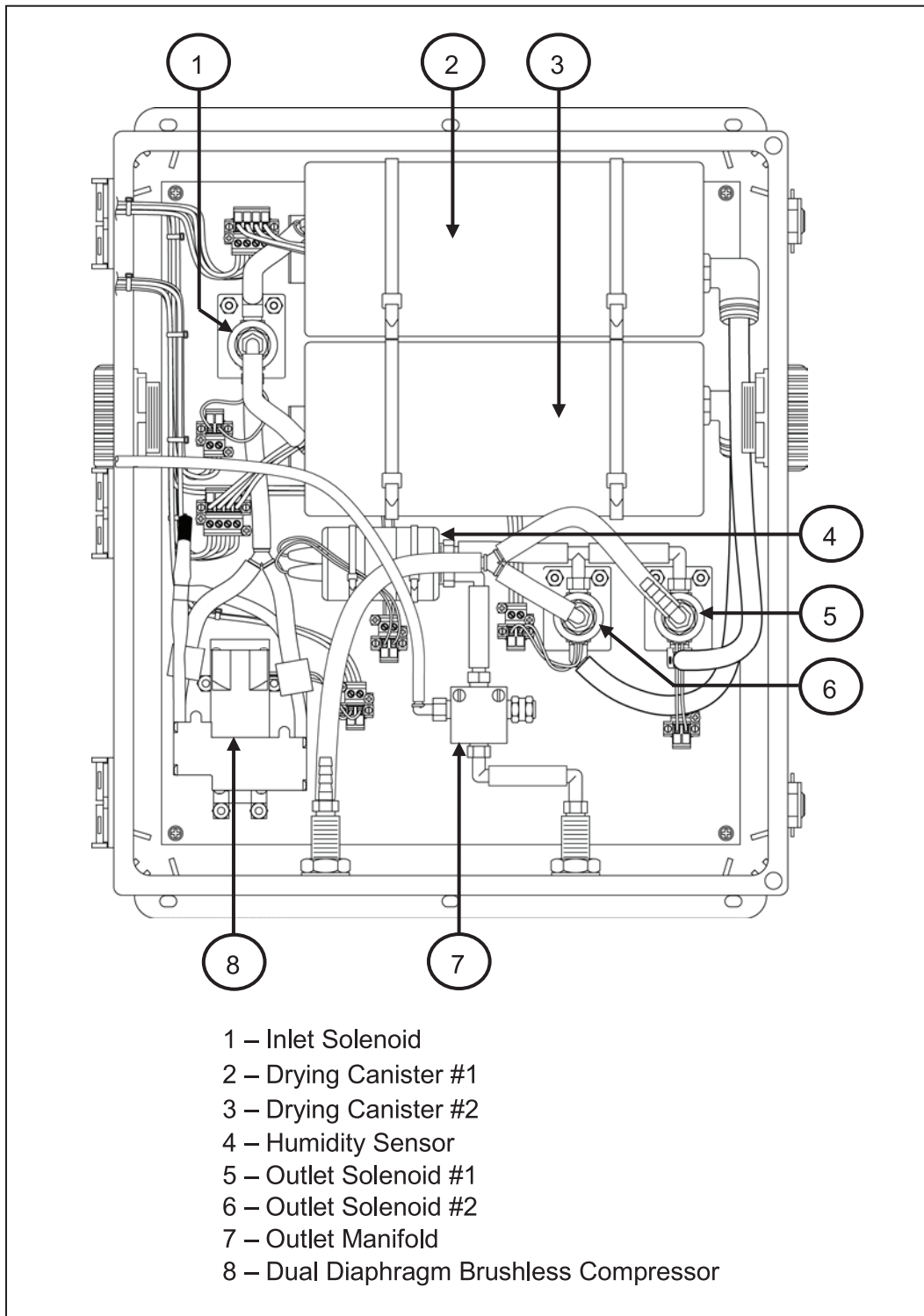

FIGURE 3. ADH NETCOM AC NEMA components.

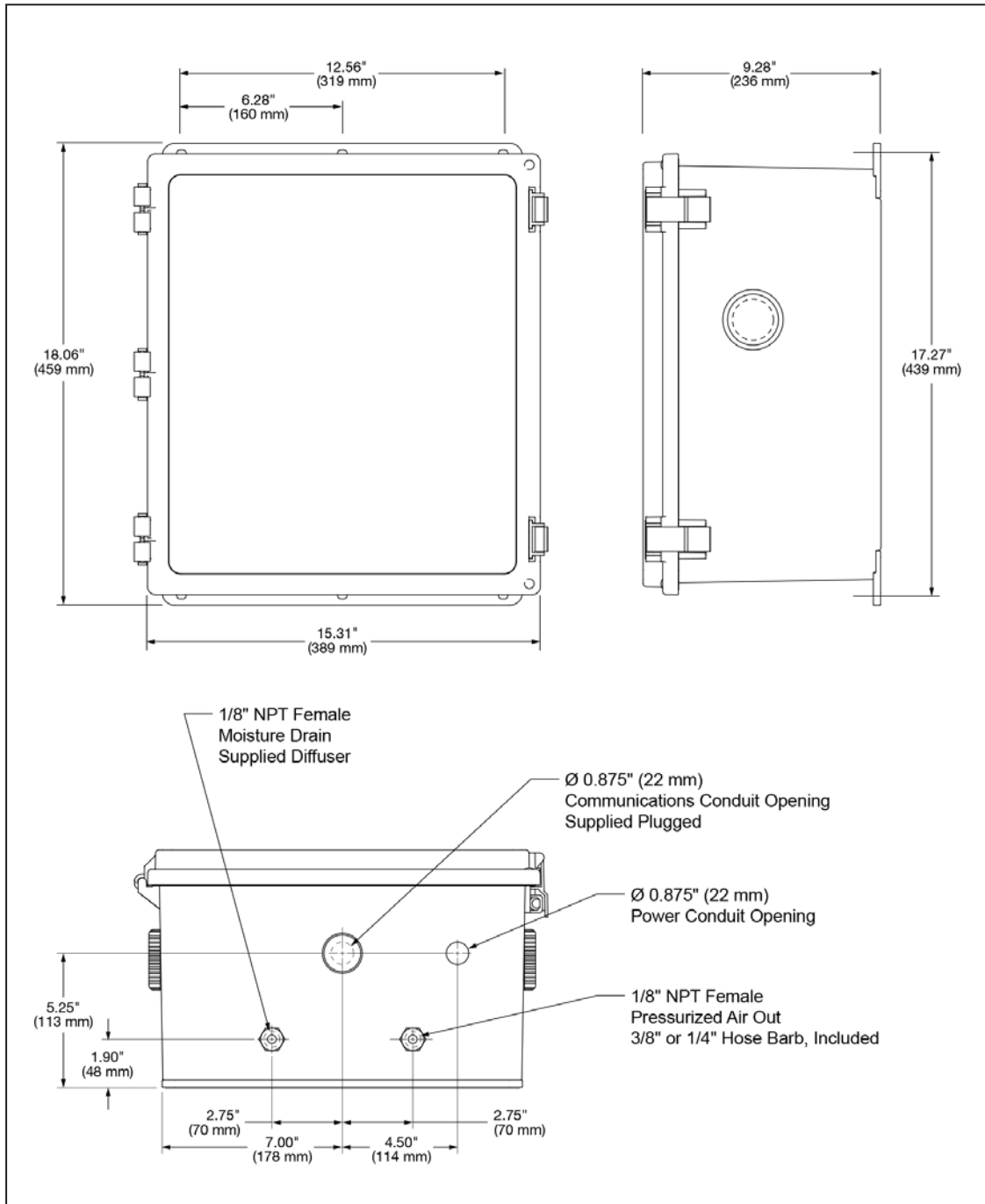

FIGURE 3. The ADH NETCOM AC NEMA enclosure dimensions.

## PREPARING FOR INSTALLATION

Prior to installing the unit, note the following information to assist in proper placement and installation. We recommend that you read these installation guidelines completely prior to beginning actual installation.

The ADH NETCOM AC NEMA automatic air dehydrator can be installed on a post or pole, on a shelf, or on a wall. Due to size and space constraints, do not mount the ADH NETCOM AC NEMA in a rack. The enclosure can be positioned with the hinges on the left side of the box (portrait), along the top of the box (landscape), or with the enclosure feet down (flat). See Figure 3.

To install the unit in the Portrait position, a suitable mounting area measuring 15.31" W x 18.06" L x 9.28" D (389mm W x 459mm L x 236mm D) must be available. The mounting hardware and the wall should be capable of supporting a static load about four times the weight of the unit, or 100 pounds (45kg).

The ADH NETCOM AC NEMA automatic air dehydrator is permanently connected equipment and does not have an internal disconnect device. A readily accessible disconnect device, short circuit, and current protection shall be provided by the customer and are not supplied by Environmental Technology, Inc. If the unit is part of a building installation or may be subject to transient overvoltages exceeding those for International Electrical

Code (IEC) Overvoltage Category II, then the customer shall also provide additional protection to satisfy IEC Overvoltage Category III and IV.

AC power shall be provided with protection that complies with UL 1449 and IEC 61643. A branch circuit with a 15A breaker for short circuit protection is required. When not using the optional Type 1 or Type 2 military connector kits, the power terminal block is suitable only with 14 AWG copper wire. A 7/8" hole is provided at the bottom of the enclosure for a conduit connection for the electrical wiring.

The customer is responsible for installing the unit in a secure, Restricted Access Location, accessible only by personnel qualified to work with this equipment.

The installation instructions presented here are divided into two sections: basic installation, followed by installation of communications cables. Basic installation presents the information necessary to get the unit installed, connected, and functioning properly. The second section addressing advanced communications installation details the installation of the communications cable(s) necessary to enable the various optional computer communications capabilities for the unit. Remember that it will be necessary to access the inside of the enclosure following basic installation in order to install the desired communications cables.

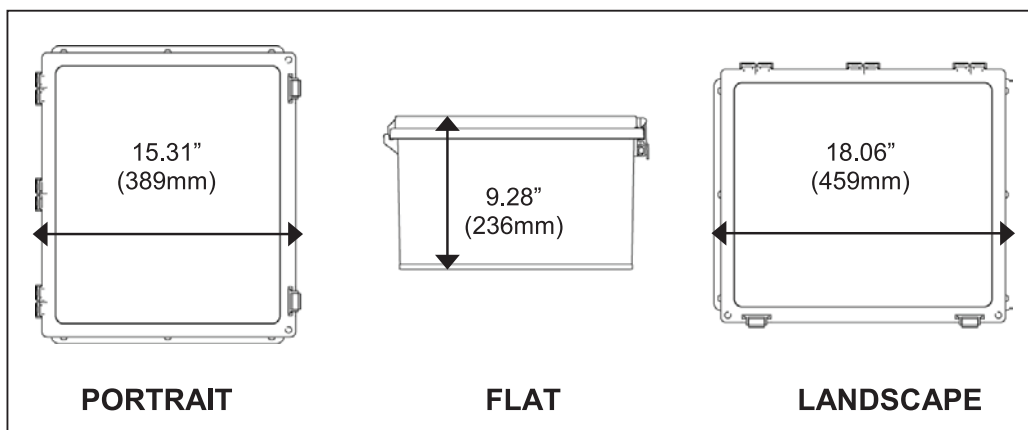

FIGURE 3. The ADH NETCOM AC NEMA in its three mounting options.

**NOTE:**

The ADH NETCOM AC NEMA automatic air dehydrator does not have a Power Switch. For that reason, remember that power is running to the unit as soon as the power source cable is connected. At this time, shut off the facility circuit breaker serving the ADH NETCOM AC NEMA.

**BASIC INSTALLATION**

To install the ADH NETCOM AC NEMA automatic air dehydrator, perform the steps below.

1. Before proceeding with installation, make sure the facility circuit breaker serving the ADH NETCOM AC NEMA unit has been shut off.
2. Using four 5/16" mounting bolts, fasten the unit to the supporting wall or surface. To ensure stable mounting, use mounting hardware of a length appropriate to the surface or material on or into which the unit is being installed. The ADH NETCOM AC NEMA unit weighs 24 lbs (10.9 kg). The installation surface or material must be capable of supporting a static load of approximately four times the weight of the unit, or 100 pounds (45kg). Fasten mounting hardware securely.
3. At this time, make the drain port connection. For this step, there are two options, as desired, depending on the installation location and function. Refer to Figure 4. Either carefully connect the bronze muffler to the fitting on the drain port (to serve as a moisture diffuser), or connect an 1/8" NPT male end barbed hose fitting to the drain port fitting, attach a hose, then route the hose to a facility drain.
4. Connect and secure the dry air supply line to the 1/8" NPT female connection at the bottom of the unit using the appropriate fitting.
5. To install the power and ground wires, run the power and ground cables inside conduit through the 7/8" access hole in the bottom of the enclosure to the inside of the enclosure. The 7/8" hole will accommodate 1/2" conduit. Leave enough slack to extend the cables to their respective terminal lugs. Remove enough of the insulation at the end of the wire or cable to be able to make the connection into their respective terminal lugs.

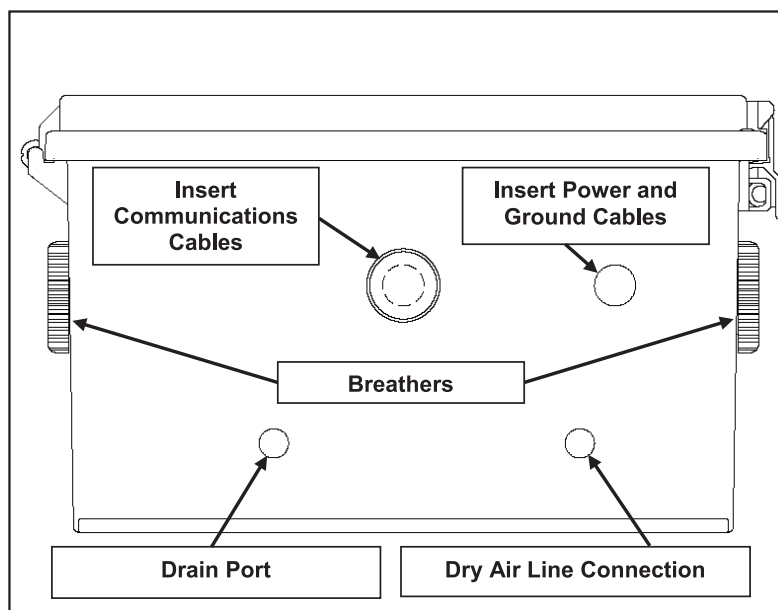

FIGURE 4. Base of NEMA enclosure.

## NOTE:

If using the bronze muffler, do not force it into place as doing so might strip the threads. If the muffler does not screw onto the drain port fitting easily, carefully unscrew it, reseal it, try screwing it in again. If using a hose connected to the drain port fitting, make sure the hose points down. The unit design prevents freezing inside the enclosure. It is the customer's responsibility to ensure that the added hose line does not freeze outside the enclosure. Finally, if using a hose, install a small filter or screen at the end of the hose to help keep bugs from getting up inside the hose.

6. At this time, connect the power and ground wires to their respective terminal lugs inside the enclosure. Refer to Figure 5. Once the power and ground wires have been connected securely inside the enclosure, seal the access hole so that no ambient air can get inside the enclosure. If desired, first seal the hole and then connect the wires.
7. Two breathers are located on the enclosure, one on either side, as shown back in Figure 4 in this appendix. They allow air into the enclosure. Do not remove the breather caps. They are specially designed to let air into the enclosure, while preventing water and dust entry. Turn the breather caps clockwise at this time just to make sure they are properly seated.

### INSTALLING THE OPTIONAL COMMUNICATIONS CABLES

With the enclosure installed and the two breathers tightened, the filter or hose connected to the drain port, the power and ground wires connected, and the enclosure power and ground cable access hole sealed, the unit is

now ready for operation. However, to take full advantage of the ADH NETCOM AC NEMA automatic air dehydrator communications capabilities, it is advised to connect, as desired, the communications cables as described below. Although the unit can now function, it cannot alert the user to any of the alarm conditions which the unit has been designed to report, nor can any reconfiguring of the unit be done remotely, without the communications cable(s) installed.

To facilitate communications with the ADH NETCOM AC NEMA automatic air dehydrator, three (3) serial ports, three (3) alarm relays, and an Ethernet port have been provided. Most often, when replacing an old unit, the RS-422/485 cable will be used. When installing a new unit that is not replacing an existing unit, the use of the Ethernet cable is recommended for monitoring unit status.

There are two ports for the RS-422/485 cable, labeled A and B, as well as a port labeled for the RS-232 cable. Of the two RS-422/485 ports, A is the female end, while B is the male end. Be careful when installing these cables

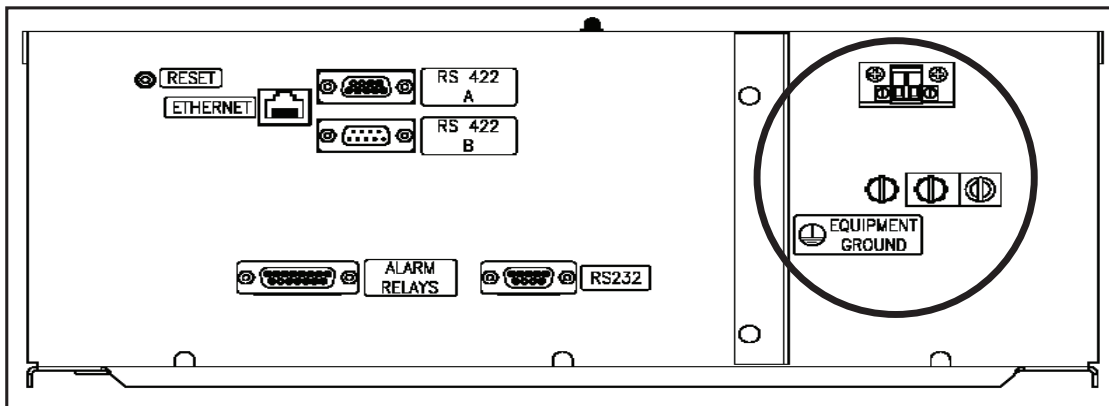

FIGURE 5. Base of NEMA enclosure.



because the female (port A) connector end of the RS-422/485 cable is the same as the connector end of the RS-232 cable. For a description of pin assignments for the RS-422/485 cable, refer back to Table 4 in the main body of this Manual. See Table 5 in the Manual for alarm relay connector pin assignments.

8. To install the communications cables, begin by unscrewing the plug cap from the bottom of the enclosure covering the weather-tight gray connector port. Separate the two halves of the plug cap by unscrewing them from each other from the inside of the enclosure. Once removed, both halves of the plug cap can be discarded. Run conduit through the access hole, then feed the cables through into the enclosure. The hole in the cap can accommodate the width of a conduit. Feed in enough cable to leave some slack for them to reach their respective ports.
9. Once the communications cables have been fed into the enclosure, connect the cables to their respective ports inside the enclosure. Refer to the labels on the enclosure, as well as to the internal interconnect diagrams for more detailed information. Refer to Figure 6. As in step 6, seal the communications cable access hole so that no ambient air can get into the

enclosure. If desired, seal the hole first, then connect the wires.

10. Once all cable connections are made and the unit is properly sealed, close and secure the enclosure using the fastening latches. Make sure the latches snap into position to make sure they are fully closed and secured.
11. Finally, once installation is complete, turn the facility circuit breaker back on and verify that the installation was successful. The unit will make a vibrating sound when the pump is operating.

### CONFIGURING THE UNIT

Now that the unit is installed and connected successfully, it will be necessary to configure or set up the specific values and performance parameters desired for your specific unit, installation, or location. Refer back to the section entitled Configuring the System, located on page 21 in the main body of this Manual.

Once the newly installed unit has been successfully configured, verify that the system pressurizes and is running at a duty cycle of less than 20%.

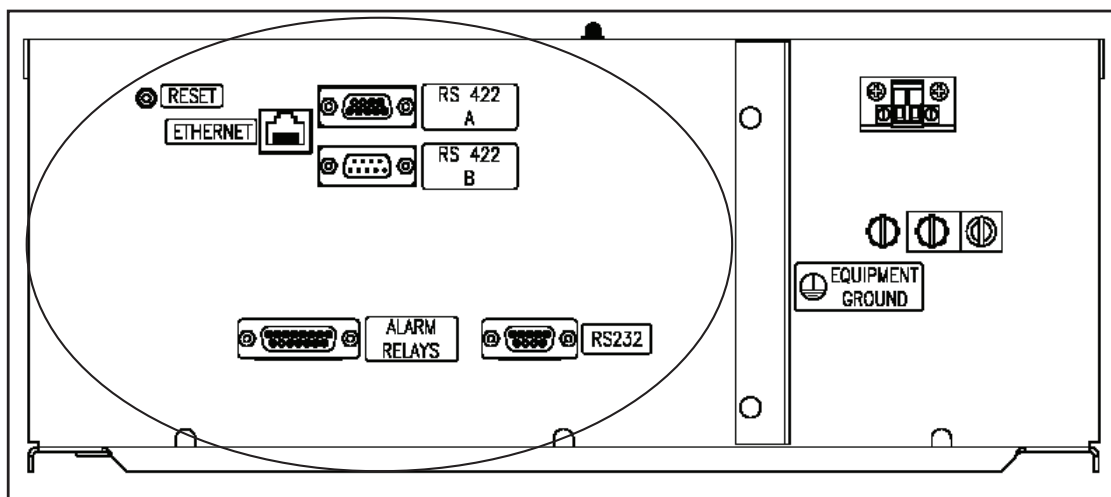

FIGURE 6. ADH NETCOME AC NEMA communications connections.

## APPENDIX B – COMMUNICATION PROTOCOLS

### OVERVIEW

On an Ethernet network, the ADH NETCOM automatic air dehydrator primarily uses the UDP network protocol for communication between an ADH NETCOM automatic dehydrator and one or more other ADH NETCOM automatic air dehydrator units. UDP is also the protocol that will be used to communicate between an ADH NETCOM unit and an ASM-1 Smart Manifold. M&C systems may also use UDP, along with or instead of SNMP.

The ADH NETCOM has three configurable serial communication ports: an RS-422/485 male port, an RS-422/485 female port, and an RS-232 female port. Each port communicates at 9600 baud by default, but may be configured as a “slow” port and communicate at 1200 baud. Only the RS-422/485 female port can be configured to use pull-up resistors or not. The RS-422/485 male port always has pull-ups.

Devices intended to communicate with an ADH NETCOM using one of its three serial ports must be configured to use a baud rate the same as that of the port to which it is connected. Additionally, the connecting device needs to be configured for seven data bits, one stop bit, and even parity.

### SERIAL COMMUNICATIONS

The ADH NETCOM air automatic dehydrator provides serial communications for directly connecting one dehydrator to another or for compatibility with legacy M&C systems. There are four configurable modes of operation: Standard mode, Terminal mode, Master mode, and Unused. Standard mode complies with the Scientific-Atlanta (S-A) protocol. In terminal mode, the unit responds in straight ASCII. Terminal mode should be used when the unit is accessed by a dumb terminal. Master mode allows a port to be used to set an ADH NETCOM as the controlling dehydrator for a standard mode dehydrator. The Standard mode dehydrator (or slave) can be another ADH NETCOM, an ADH-2A COM, or an ADH-3COM. If a port is not going to be used, configure it as Unused.

### STANDARD MODE COMMAND FORMAT

A valid command in the standard mode must consist of the following: The first character is STX (2 Hex) and is followed by the remote address. Next, the command you wish to execute and the associated data bytes are transmitted. ETX (3 Hex), and the checksum are then sent to conclude the transmission.

### STANDARD MODE RESPONSE TO A COMMAND

The response format of the unit is identical to the command format, except for the first character. If the command was understood, an ACK (06 Hex) will replace the STX character. If the command was not understood or cannot be acted upon, the response will begin with an NAK (15 Hex) and the data bytes will not be returned. Only the NAK, address, command, ETX, and the checksum will be sent.

### CHECKSUM CALCULATION

The checksum is a bitwise exclusive - or of all the characters in the stream. This includes the STX and the ETX characters.

### TERMINAL MODE COMMAND FORMAT

When the unit is placed in Terminal mode, the only valid command is the carriage return (0D Hex). This requests the unit for the status.

### TERMINAL MODE RESPONSE FORMAT

Terminal mode is straight ASCII. The end of line delimiters can be configured as a carriage return (CR), a line feed (LF) or as both.

### USER DATAGRAM PROTOCOL

The ADH NETCOM automatic dehydrator uses the User Datagram Protocol (UDP) network protocol for communicating with one ADH NETCOM automatic air dehydrator and any of the following:

- another ADH NETCOM automatic dehydrator;
- an ASM-1 Smart Manifold; or
- M&C (Monitor and Control) systems.

The ADH NETCOM automatic dehydrator receives commands on UDP port 52091.

When operating as a master dehydrator in master/slave configuration, the master will send out messages using UDP port 52092 as the source port and 52091 as the destination port. In addition, when resolving dehydrator names to an IP address, the ADH NETCOM master will use NetBIOS Name Service (NBNS) on UDP port 52090.

## MESSAGE FORMAT

### *S-A Protocol*

An S-A protocol query to an ADH NETCOM will consist of the following:

- STX: 02 hex
- S-A Address: configurable to a hex value from 30 to 6f
- Command Character: See list of commands
- Message Data: Zero or more data bytes
- ETX: 03 hex
- Checksum: Exclusive-or of all the other bytes in the message including the control bytes.

The response to a message is in the same form as above, except that the STX is replaced with either an ACK (06 hex) if the message is accepted or a NAK (15 hex) if the message is rejected. The address and command characters of the response must always match the address and command characters of the command. The sender of the command does not have a relevant S-A address.

### *UDP Protocol*

A UDP message to an ADH NETCOM consists of the following:

- C: 43 hex; C stands for command
- Index: a one-byte field used to match a query to a response
- Command Character: See list of commands
- Zero or more data bytes

The response to a message is in the same form as above, except that the first character is replaced with a return code. The return code will be one of the following:

- Y: Command accepted and acted upon if relevant
- N: Command rejected
- ?: Command not valid

### *Commands*

Command characters are referred to either as a quoted character (using single quotes) or as that character's hex value. For example, if you wish to determine the model of automatic dehydrator to which you are communicating, consider using either '0' or 30 hex as the command character.

### *Command Group 1*

These commands were documented with the ADH-2A COM and ADH-3COM automatic air dehydrators.

'0' - 30 hex - Returns a 6-character ID string. This string is always "NETCOM" for ADH NETCOM automatic air dehydrators. An ADH-3COM may return ADH331, indicating that the ADH-3COM is using software version 3.1.

'1' - 31 hex - Returns a status string.

This command is included for backward compatibility with Environmental Technology, Inc.'s ADH-3 and related products. Refer to the ADH-3 manual for details if necessary. The use of this command is not recommended in new applications, since it supplies only a subset of the information available.

'7' - 37 hex - Go into stand-by. For master/slave configurations, this command will put the master/slave set into stand-by.

## NOTE:

In the communications set-up screen, the user can choose between English and metric, as well as one of three pressure ranges. The **ONLY** use of those settings is in the form of the return for the '1' command.

'8' - 38 hex - Go online. For master/slave configurations, this command will put the master/slave set online. The specific automatic air dehydrator which will actually be placed online is still controlled by the master.

## COMMAND GROUP II

Though these commands were not documented with the ADH-2ACOM and ADH-3COM automatic air dehydrators, they were used in the master/slave interface.

'2' - 32 hex - Returns a special character call qstat1. See the notes below.

'5' - 35 hex - The same as '2', but sets the communications error flag in the slave.

'J' - 4a hex - Puts the slave into remote mode.

[' - 5b hex - Sets a flag to turn on the slave compressor if in remote mode.

]' - 5d hex - Sets a flag to turn off the slave compressor if in remote mode.

### Notes on this group:

The command '2' returns what we call qstat1: it is a single character encoding important elements of the dehydrator's status.

The low bit (bit 0, binary 1) is set if the unit is "reluctant": this means that it is capable of pressurizing, but would have to use a canister which is or may be wet to do so. We avoid giving control to the slave when it is reluctant, if it is possible to do so.

The second bit (bit 1, binary 2) is set if the unit is currently pressurizing - i.e., the pump is running and aimed at the antenna (although there may be a brief lag of up to 100msec).

The rest of the byte is 'A' (40 hex) plus a state index multiplied by 4. The state index is:

0: On line

1: Stand-by

2: Leaky (Stopped pumping because of a declared leak)

3: Remote (Compressor on or off, according to commands from master)

4: Alternating (Not used, included for legacy compatibility.)

5: Joint (The master's state during parallel pumping.) (Not yet implemented.)

The reason for the '5' command is that it is possible that communications from the master to the slave may be intact but that the return path from the slave to the master could be broken. In that case, the master will not know the slave's status, and will continually broadcast commands to determine it. The slave receives all these commands normally. Without the '5' command, the slave would not declare a communications error and would stay in stand-by forever.

## COMMAND GROUP III:

### COMMANDS NEW TO THE ADH NETCOM

'9' - 39 hex - The NETCOM returns a string whose first character is 'N', identifying it as a NETCOM. This is mainly to allow the NETCOM to determine whether a slave is a NETCOM or a legacy (earlier) dehydrator. Though this may change in the future, at the time of this writing, the string is 'N2'.

'E' - 45 hex - Returns current status, in English units.

'M' - 4d hex - Returns current status, in metric units. See the next section.

Note: this is a fixed-length string, giving the most important information about the status of the NETCOM.

'L' - 4c hex - Alarms, form 1. This is a fixed-length string, with the Nth character being a '+' if alarm N is set, or a '-' if it is not. The length is 22 characters.

'R' - 52 hex - Alarms, form 2. This is a variable-length string, with two characters for each alarm which is present,

giving the number of the alarm (the first character is '0' if the alarm number is less than 10).

'T' - 54 hex - Compressor run time. Return is a variable-length string: a number with one decimal place (the decimal point is included in the string: as "12.3"). This represents approximate accumulated compressor time, in hours.

'C' - 43 hex - Configuration information. The result is a fixed-length string of the form "Xaaabbbccddd". This gives the current pressure limits. If the first letter is E or e, the limits are given in hundredths of a PSI. If the first letter is M or m, the limits are given in mbar. A lower case letter means that it is configured as a small system. The aaa is the lower pressure alarm, the bbb is the lower limit, the ccc is the upper limit, and the ddd is the high pressure alarm limit.

'I' - 49 hex - ID information. The response is a variable-length string with two sub-strings, separated by a semicolon. The first substring is the name of the firmware in the NETCOM. The second is the serial number of the unit.

'Q' - 51 hex - Enhanced quick status (similar to the '2' command). The return is a four-character string. The first character is the same as is returned by the '2' command. The next three characters are the pressure in hundredths of a PSI (there is no metric equivalent for this command).

**Meaning of the string for the E and M commands:**

Chars 0,1,2: the current pressure, in hundredths of a PSI or in mbars

Chars 3,4,5,6: current temperature, in degrees F or C. Character 3 is + or -

Chars 7,8,9: duty cycle, in percent.

Char 10: descriptor for "superstate": only important for a master:

S: Unit is a slave

M: Unit is a master, and system is online

N: Unit is a master, and whole system is in stand-by

D: Unit is a director, and system is online

E: Unit is a director, and whole system is offline

(Note: Director mode is not yet implemented.)

Char 11: descriptor for major state:

N: On line

S: Stand-by

L: A leaky system; not attempting to pump

R: Remote mode: pumps as directed by master

A: Alternating: not used (legacy state)

J: Joint: the master's state during parallel pumping

(Note: This feature is not yet implemented.)

Char 12: state of the environment (temperature):

N: normal

C: cold

H: hot

Char 13: condition of canister 1:

O: Okay; normal, dry

F: Full; wet

U: Unknown; used for a while after unit is powered up

D: Dead; failed to regenerate and will not be used if avoidable.

Char 14: usage of canister 1:

I: idle (not being used)

U: in use (for pressurization)

R: being regenerated

Char 15: condition of canister 2: as in char 13

Char 16: usage of canister 2: as in char 14

Char 17: 'A' if there is an alarm condition, '-' if not.

## THE X COMMAND

The X command is used to “forward” a command through the master ADH NETCOM automatic dehydrator to a slave unit when they are connected via a serial connection. The X command will not function for master and slave sets connected via Ethernet where the master and slave can each be directly communicated with.

There are two forms of the X command:

- **Form One** - One data byte, the command to forward. The address is understood to mean the slave.
- **Form Two** - Two data bytes: the first is an address, the second the command to forward. The address byte must be either '1', meaning forward to the slave, or '0', meaning the recipient should do it himself.

If the command is to be forwarded and the unit is not a master, the X command will be rejected. The X command will be accepted if it is possible to forward it to a slave, even if we know that the slave will reject it. This is to allow the possibility that in the future the slave will have features that the master does not have.

There are certain commands that are never forwarded. At the moment, this includes the '7' and '8' commands, the 'J' and '[' and ']' commands (all of which can cause an actual effect on the slave), as well as the X command itself.

The response to the X command is as follows:

- **First data byte:** repeat of the address character ('0' or '1')
- **Second data byte:** repeat of the command being forwarded
- **Third data byte:** status of the command

After this, comes any returned data.

The status bytes are:

- Y: Slave returned an ACK
- N: Command returned a NAK
- T: Command timed out: no return within 1/2 second
- B: System too busy to send command.

## Example S-A Communication Session

Suppose we wish to communicate with an ADH-3COM that has no address jumpers set, making the user-selected address 0. Then we add 30 hex to this number (remember, 30 hex gets added to every address). This makes for a final address of 30 hex for this ADH-3COM. Now, suppose we wish to retrieve the unit's status. The command line we use is 31. Following is the string of bytes that must be sent:

02, 30, 31, 03, 00

The bytes, in order, are STX, ADDRESS, COMMAND, ETX, CHECKSUM.

A typical response may be:

06, 30, 31, 45, 30, 31, 33, 2b, 30, 36, 30, 55, 52, 30, 31, 30, 30, 31, 35, 2d, 2d, 2d, 2d, 2d, 2b, 2d, 2d, 2d, 2d, 2d, 2d, 2d, 57, 20, 03, 30

This message decodes as follows:

06, 30, 31 = STX, ADDRESS, COMMAND

45, 30, 31, 33 = E013 = English, 0.13 psig. The decimal point is assumed and its location is determined by pressure and display options.

2b, 30, 36, 30 = +060 = +60°F

55, 52 = UR = Absorption unit #1 in use, absorption unit #2 regenerating.

30, 31, 35 = 015 = 0.015cfm flow rate  
2d, 2d, 2d, 2d, 2d, 2b, 2d, 2d, 2d, 2d, 2d, 2d, 2d, 57, 20 = --W = Indicates that Warning 6 (low line voltage) has been issued and no alarms are present.

03, 30 = ETX, CHECKSUM

### NOTE:

The 13 data fields following the flow rate field correspond to the alarms and warnings shown on page 29 of this manual.

# APPENDIX C – MASTER CONFIGURATION

## PURPOSE

An ADH NETCOM automatic air dehydrator can be configured as a master dehydrator to control another ADH NETCOM, an ADH-3COM, or an ADH-2A COM automatic air dehydrator. The connected master/slave dehydrator pair can be connected to the same pressurization system to provide redundancy and increase the system reliability.

## DESCRIPTION

The two air dehydrators in the master/slave configuration communicate with each other over an Ethernet network or directly connected via the serial RS-232 or RS-422/485 ports. If paired with an ADH-2A COM or ADH-3COM, the ADH NETCOM must connect via an RS-422/485 connection. The interface cable wiring connection is shown in Figure 1. The master and slave units must have the same baud rate set for serial RS-232 and RS-422/485 connections. It is recommended to use 9600 baud in the master/slave configuration.

Under normal conditions, the master and slave unit will alternate control of air dehydration in the waveguide system, each being on line for 50 hours. When one unit is in control, the other will be in a stand-by mode.

Three conditions will cause an ADH NETCOM to relinquish control to the connected dehydrator. The three conditions are:

- Unit unable to perform air dehydration;
- Unit unable to attain desired pressure; and
- Master/slave communication failure.

Condition 1 would occur if both absorption units in the air dehydrator fail or an absorption unit has failed and the other needs to be regenerated. Once a unit has relinquished control for this condition, it will not get it back unless the condition goes away.

Condition 2 would exist if a unit runs for one hour without attaining the desired pressure. The unit declares itself leaky. This is a permanent condition, unless the other unit also declares itself leaky.

Condition 3 would occur either if the master does not receive a response from the slave in 5 minutes, or if the slave does not receive a message from the master in 15 minutes.

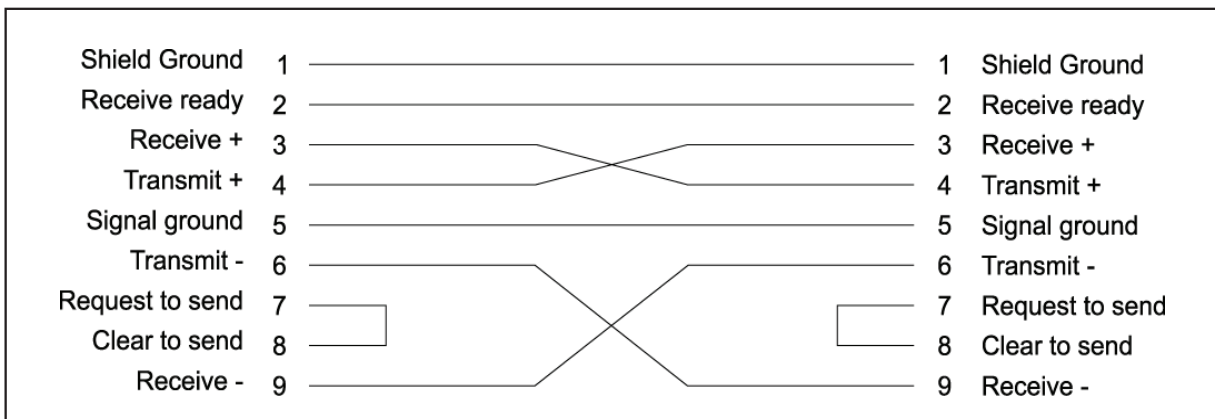

FIGURE 1. Interface cable wiring connection.

## APPENDIX D – OPTIONAL FRONT PANEL

### INTRODUCTION

The ADH NETCOM automatic air dehydrator optional front panel with 3-position rocker switch allows the operator to view current system status or change the dehydrator's IP information. Refer to Figure 1. Pressing the rocker switch in the middle, directly on the display screen itself, works like an Enter button. Pressing the top or bottom of the rocker switch will scroll up or down, respectively, to highlight the different lines on those screens with several user options.

The display shown in Figure 1 is the current system pressure status screen. This is the screen which will be displayed most of the time. From this screen, all other system screens and functions are accessible. The top line is the current unit of measure for the system pressure reading (in PSI or mbar). The second line, in larger type, is the actual current system pressure reading. The third line displays any current alarm conditions. Should there be more than one current alarm condition, the third line on the system pressure status screen will display all current alarm conditions in succession.

After a fixed period of 10 minutes, the display enters the screen saver mode. The screen saver is a small image of the ETI company logo (as seen at the top of this page) which will flash quickly then disappear and will repeat about every 2 seconds. If there are any current alarm conditions, an alarm symbol consisting of an exclamation point inside a triangle will be displayed instead of the ETI logo.

### REPLACING THE FRONT PANEL (SHELF OR RACK MOUNT)

1. Shut off unit power by turning the Power Switch on the back panel to the OFF (O) position.
2. Remove and retain the four sets of screws and flat washers securing the forward top panel to the unit, then remove the forward top panel. Leave the rear top panel in place.
3. Carefully disconnect the four existing LED leads, one at a time. Do not disconnect the black or red power wires in the far left-side terminals. To release the leads, use a flat blade screwdriver and gently press in on the release tab below each lead, then remove the lead. Repeat and disconnect all four LED leads.

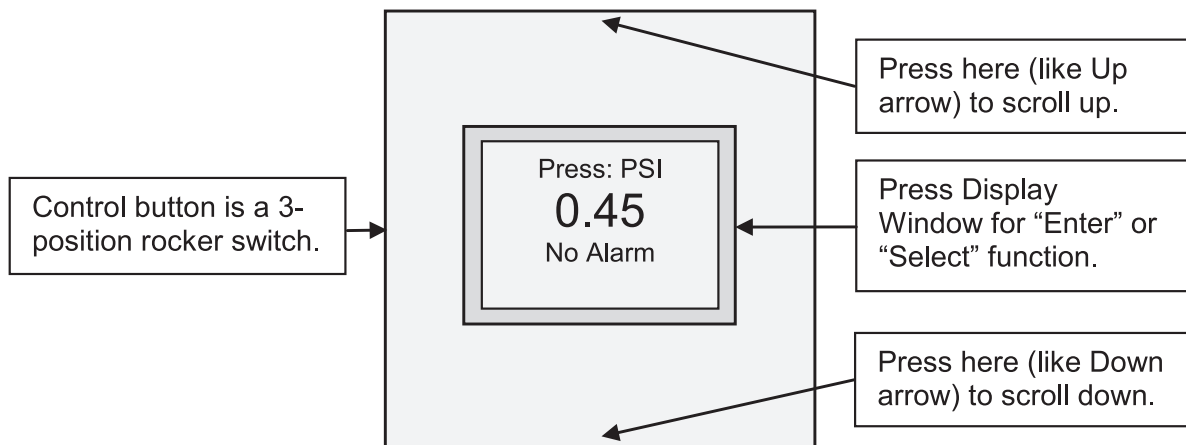

FIGURE 1. The ADH NETCOM system pressure status screen.



4. Remove and retain the four screws securing the existing front panel to the unit, then remove the front panel.
5. Install the new front panel using the four screws removed in step 4.
6. Install the four LED leads from the new front panel into the proper terminals as shown in the diagram below. Once the proper terminal has been identified for each specific lead, connect a new LED lead. Using the screwdriver, press the release tab in, then insert the lead. Remove the screwdriver to allow the release tab to close and secure the lead in place. Repeat until all four leads have been installed.
7. Carefully plug in the ribbon cable. Make sure to position it correctly; it can be installed only one way. Make sure that both release tabs are properly seated once the ribbon cable is installed.
8. Reinstall the forward top panel of the unit using the mounting hardware removed in step 2.
9. Restore unit power by moving the Power Switch to the ON (I) position.

### REPLACING THE FRONT PANEL (WALL MOUNT)

1. Shut off unit power by turning the Power Switch on the back panel to the OFF (O) position.
2. Remove and retain the four screws securing the existing front panel to the unit, then partially remove the front panel. Be careful; the LED leads are still connected to the terminal block.
3. With the existing front panel out of the way, carefully disconnect the four existing LED leads, one at a time. Do not disconnect the black or red power wires in

the far left-side terminals. To release the leads, use a flatblade screwdriver and gently press in on the release tab below each lead, then remove the lead. Repeat and disconnect all four LED leads.

4. Once all four LED leads have been disconnected, remove the front panel.
5. Position the new front panel near the unit so that the LED leads reach the terminal block. Install the leads from the new front panel into the proper terminals as shown in the diagram below. Once the proper terminal has been identified for each specific lead, connect a new LED lead. Using the screwdriver, press the release tab in, then insert the lead. Remove the screwdriver to allow the release tab to close and secure the lead in place. Repeat until all four leads have been installed.
6. Carefully plug in the ribbon cable. Make sure to position it correctly; it can be installed only one way. Make sure that both release tabs are properly seated once the ribbon cable is installed.
7. Install the new front panel using the four screws removed in step 2.
8. Restore unit power by moving the Power Switch to the ON (I) position.

### OPERATION

This section describes the four basic functions you can perform using the rocker switch. These are:

- setting the display brightness level;
- scrolling through the system status screens;
- setting a fixed IP address; and
- selecting DHCP mode.

<b>24V Ground</b> Black wire	<b>+24V Power</b> Red wire	<b>GRN LED</b> White wire	<b>GRN LED</b> Red wire	<b>RED LED</b> White wire	<b>RED LED</b> Red wire
-------------------------------------	-----------------------------------	------------------------------	----------------------------	------------------------------	----------------------------

### LED LEAD WIRING DIAGRAM

### Setting the Display Brightness Level

With settings from 15 at the brightest to 2 at the dimmest, the display brightness level can be set to be brighter or dimmer, as desired. It is advised, however, that to prolong the life of the display unit, a dimmer setting be used. As greater brightness will likely be required while actively configuring the unit, consider using a brighter setting while actually making or changing system settings, then turning the brightness level back down following configuration. This will help prolong the life of the display unit.

To change the display brightness level, perform the steps below:

1. Press and hold the middle of the rocker switch until the screen with the topline of IP addr appears. The top line should already be highlighted.
2. Use the lower edge of the rocker switch to scroll down to highlight the middle two lines on that screen: Brghtnss Level.
3. With the middle two lines on the screen highlighted, press the middle of the rocker switch to select it. The highlight will now narrow to include just the actual setting number.
4. Using the upper or lower edges of the rocker switch, respectively, to increase or decrease the setting, adjust the display brightness level as desired. When finished, press the middle of the rocker switch again to confirm the new value. The middle two lines on the screen will be highlighted again.
5. Using the lower edge of the rocker switch, scroll down to highlight Return, then press the middle of the rocker switch to select it. The display will now show the system pressure status screen.

### Scrolling Through the System Status Screens

In addition to the system pressure status screen described in Figure 1, several other screens also display system status information. Press the upper or lower edge of the rocker switch and they will display in turn.

**Temperature** - Expressed in degrees F or degrees C

**Canister Status** - The Canister Status screen shows the condition status and usage status of each canister, using 3-letter codes. The condition codes are:

INI -	Initial; the initial state of the dehydrator
RDY -	Ready; the normal condition
WET -	Wet or full; needs to be regenerated
DED -	Dead; failed regeneration

Separated from the usage code by a slash mark, the usage codes are:

IDL -	Idle
USE -	In use (for pressurization)
REG -	Being regenerated

**System Status** - The first line presents the "super state."

Slave -	displayed if the unit can be controlled by another unit
Master -	displayed if the unit is controlling another unit
MastrOff -	indicated if a Master and its slave are both in standby

The second line on the System Status screen displays the operating state

Normal -	the unit is pressurizing on its own; it controls when it pumps
Standby -	the unit has been directed not to pump
Leaky -	unable to pressurize; will be indicated as an error condition
Remote -	another device is controlling its operation

**Duty Cycle** - Displays active compressor time; expressed as a percentage

**Cycle Information** - The Cycle Information screen presents information in seconds (s) or minutes (m). The "On" number is the length of time the compressor is actively pumping; the "Tot" number is the total cycle time, including both the pumping time ("ramp up") and the time in between pumping cycles ("ramp down") before the next pumping cycle starts.

**Compressor Hours** - cumulative service over the compressor lifetime; in hours

## VIEWING THE CURRENT IP SETTINGS

To view the current IP settings, perform the steps below:

1. From the system pressure status screen, press and hold the middle of the rocker switch until the display changes.
2. The top line on the next screen is IP addr and that top line should already be highlighted. Press the middle of the rocker switch to select it.

### NOTE:

Steps 3a and 3b below both describe the same process but for the two different modes: IP:Fixed or IP:DHCP. Because the current mode might not be known, instructions for both are included, though only one will apply for each unit.

- 3a. If the top line of the next screen is IP:Fixed, select the Show Val line to view the information. There are three screens in the series: one for the IP address, one for the subnet mask, and one for the gateway. Press the middle of the rocker switch to advance to the next screen. From the gateway screen, press the middle of the rocker switch, then on each of the next two screens, scroll down to highlight Return and press the middle of the rocker switch. The system pressure screen will display.
- 3b. If the top line of the next screen is IP:DHCP, there are two available options: ShowName and Show Addr. To view the current network name associated with the unit, select the ShowName option then press the middle of the rocker switch. Press the rocker switch again to return to the DHCP screen. To view the actual IP address of the unit as assigned by the DHCP server, assuming there even is one yet, select the ShowAddr option, then press the middle of the rocker switch to proceed. There are three screens in the series: one for the IP address, one for the subnet mask, and one for the gateway. Press the middle of the rocker switch to advance to the next screen. From the gateway screen, press the middle of the rocker switch, then on each of the next two screens, scroll down to highlight Return and press the middle of the rocker switch. The system pressure screen will display.

## CHANGING THE IP ADDRESS

When changing the unit's IP address, subnet mask, or gateway, your own IT Department is the best source of information regarding what these numbers need to be. There is nothing arbitrary about them. Every system is unique and each one has specific communications requirements. Before changing any of the IP-related settings, check first with your IT Department or administrator to determine the exact communications requirements for your specific system devices.

It is important to remember that any change made to the IP address will need to be communicated to every device in the system. This includes an ASM®-1 Smart Manifold™ automated air distribution manifold, if a part of your system, dehydrators serving either as master or slave units along with other dehydrators, as well as any M&C (monitor and control) computer running with your network.

## CHANGING A FIXED IP ADDRESS

### Warning Note

When changing the IP address, it might not be necessary to change both the mask and gateway settings, though the gateway setting might need to change depending what changes are made to the IP address. These numbers must be consistent. Your own IT Department or administrator is the best source of information regarding what these settings should be. You should, in fact, already know what these numbers need to be even before you begin this process.

To change a Fixed IP address, perform the steps below:

1. From the system pressure status screen, press and hold the middle of the rocker switch until the display changes.
2. The top line on the next screen is IP addr and that top line should already be highlighted. Press the middle of the rocker switch to select it.
3. If the top line on the next screen is IP:DHCP, then refer to the next section of this manual: Selecting DHCP Mode. If the top line on that next screen is already IP:Fixed, then proceed with step 4 below.

4. On the IP:Fixed screen, use the lower edge of the rocker switch to scroll down to highlight the third line: Edit Val. Press the middle of the rocker switch to select it.
5. When the Fix:Addr screen appears, the first of four fields which comprise the IP address will be highlighted. Use the upper or lower edges of the rocker switch, respectively, to increase or decrease the number to the desired setting, then press the middle of the rocker switch to advance to the second field.
6. When the second field is highlighted on the Fix:Addr screen, repeat the process described in step 5 above, using the upper or lower edge of the rocker switch to increase or decrease the number to the desired setting. Repeat this process until all four fields are set as desired. If you make a mistake and need to enter a new setting, scroll down to Can(cel), press the middle of the rocker switch, then select Edit Val from the IP:Fixedscreen. Once the entire address is set as desired, scroll down to highlight Next, press the middle of the rocker switch to select it, and the Fix:Maskscreen will display.
7. The fixed mask can also be changed as desired, but it is changed in a different way than the IP address was changed. On the Fix:Mask screen, the entire mask is changed all at once using the upper and lower edges of the rocker switch to change it to the desired setting. As the mask is a different type of setting than either the IP address or the gateway, the change procedure for it is also different. Make any desired changes to the mask using the upper and lower edges of the rocker switch to change the number. If you make a mistake and need to enter a new setting, scroll down to Can(cel), press the middle of the rocker switch, then select EditVal from the IP:Fixed screen. Once the mask is set as desired, press the middle of the rocker switch to highlight Next, then press the middle of the rocker switch to proceed to the Fix:Gate screen.
8. On the Fix:Gate screen, similar to the Fix:Addr screen, the four fields comprising the gateway highlight individually and are changed individually rather than all at once as they were on the Fix:Mask screen. Repeat the process described in step 5 above to change the gateway to the desired setting, pressing the middle of the rocker switch to advance to the next field. Note that because the gateway setting must be numerically consistent with the IP address, some of the gateway numbers might change automatically to reflect this fact. Begin with whatever gateway setting is shown, then change each field as desired. If you make a mistake and need to enter a new setting, scroll down to Can(cel), press the middle of the rocker switch, then select Edit Val from the IP:Fixedscreen. Once all four fields of the gateway have been set as desired, scroll to highlight Next at the bottom of the Fix:Gate screen, then press the middle of the rocker switch to select it.
9. The screen displayed after selecting Next on the Fix:Gate screen is the change confirmation screen and presents several options. If you need to go back and re-do any of the changes you just made, highlight and select the Re-Edit option. You will see displayed the screen you used to begin the change process. If you need to cancel all of the changes you just made, highlight and select the Cancel option at the bottom of the confirmation screen. You will see displayed the IP addr screen. Highlight and select IP addr to begin again and go back to step 4 of this procedure. Once you are satisfied with the changes you made in this procedure, highlight and select the Keep option and the message will display that the machine is going to reboot.
10. Rebooting is automatic; no operator action is required. Once the reboot is complete, be sure to communicate the changes to all system devices so that communications between them is not lost or interrupted. Proceed with normal operations or with additional system configuration, as desired, as described in the ADH NETCOM Instruction Manual.

### SELECTING DHCP MODE

Unlike changing a fixed IP address where the operator has to manually change the various fields on the screen, in DHCP mode, the software itself does the bulk of the work automatically, invisible to the operator.

Before continuing, make sure that the unit is connected to your network.

To select DHCP mode, perform the steps below:

1. From the system pressure status screen, press and hold the middle of the rocker switch until the display changes.
2. The top line on the next screen is IP addr and that top line should already be highlighted. Press the middle of the rocker switch to select it.
3. If the top line on the next screen is IP:Fixed, then refer back to the previous section of this manual: Changing a Fixed IP Address. If the topline on the next screen is already IP:DHCP, proceed with step 4 below.
4. On the IP:DHCP screen, use the lower edge of the rocker switch to scroll down to highlight Return at the bottom of that screen, then press the middle of the rocker switch. Now displayed is the IP Info: screen.
5. Scroll down to highlight Keep, then press the middle of the rocker switch to select it. You will now see a message indicating that the IP information has changed and that the software is "Resetng" (resetting) or rebooting the unit. The machine will now automatically reboot. It might take a few minutes to acquire an IP address from the DHCP server, so be patient. The rebooting itself takes only a few seconds.
6. To confirm that the change process was successful and that the machine is now in DHCP mode, from the system pressure status screen, press and hold the middle of the rocker switch until the IP addr screen appears with that top line already highlighted. Press the middle of the rocker switch and the IP:DHCP screen will appear.
7. Scroll down to highlight ShowName, then press the middle of the rocker switch to select it. Write down the unit name for reference. Press the middle of the rocker switch to return to the previous screen.
8. Now, highlight ShowAddr, then press the middle of the rocker switch to select it. You should see the unit's IP address. If you see all 0s on the screen or an error message, contact your IT Department or administrator. Write down the unit's IP address for reference. From this screen, press the middle of the rocker switch and the mask will display. Write it down for reference. Press the middle of the rocker switch again and the gateway will display. Again, write it down for reference. Now, press the middle of the rocker switch again then, on the IP:DHCP screen, scroll down to highlight Return, then press the middle of the rocker switch one last time to display the IP addr screen. Scroll down to highlight Return on this screen, as well, then press the middle of the rocker switch to return to the system pressure status screen.
9. Once this process is complete, to access the unit using Ethernet, use either the IP address or the unit name in the web browser. Make sure to communicate the new IP information to all devices in the system so that communications between them is not lost or interrupted. At this time, proceed with normal operations or additional system configuration, as desired, as described in this manual.

## ORDERING INFORMATION

PART NUMBER	DESCRIPTION
25526	ADH NETCOM Automatic Air Dehydrator, AC
25527	ADH NETCOM Automatic Air Dehydrator, DC
25523	ADH NETCOM Automatic Air Dehydrator, AC, NEMA
24486	Front Panel, ADH NETCOM Automatic Air Dehydrator, W/Display
25524	ADH NETCOM NEMA Automatic Dehydrator, 100-240 VAC(w/ Mil-Spec Connectors Type 1)
25525	ADH NETCOM NEMA Automatic Dehydrator, 100-240 VAC(w/ Mil-Spec Connectors Type 2)
25548	ADH NETCOM with Redundant DC Power Installation Sheet
25549	ADH NETCOM NEMA with AC Power Installation Sheet
25546	ADH NETCOM with AC Power Installation Sheet

--	--

ACCESSORIES	DESCRIPTION
23739	ADH NETCOM NEMA Mil-Spec Type 1 Connector Accessory Kit (for 25523)
23883	ADH NETCOM NEMA Mil-Spec Type 2 Connector Accessory Kit (for 25523)

## CONTACTING CUSTOMER SERVICE

For assistance, contact Customer Service. Office hours are from 8:00 AM until 5:00 PM ET.

**Email:** [info@networketi.com](mailto:info@networketi.com)

**Web:** [networketi.com](http://networketi.com)

**Mail:** Environmental Technology, Inc.  
1850 North Sheridan Street  
South Bend, IN 46628

## LIMITED WARRANTY

ETI's two year limited warranty covering defects in workmanship and materials applies. Contact Customer Service for complete warranty information.

## DISCLAIMER

Environmental Technology, Inc. makes no representations or warranties, either expressed or implied, with respect to the contents of this publication or the products that it describes, and specifically disclaims any implied warranties of merchantability or fitness for any particular purpose. Environmental Technology, Inc. reserves the right to revise this publication, and to make changes and improvements to the products described in this publication, without the obligation of Environmental Technology, Inc. to notify any person or organization of such revisions, changes or improvements.